

CR-60 Cornerounder[®]

USER'S MANUAL



ProSource Packaging, Inc.
14911 Stuebner Airline Suite A
Houston, TX 77069
800-203-0233
www.Machine-Solution.com

Serial Number: _____
Date of Purchase: _____
Dealer: _____
Address: _____

Telephone Number: _____

Before operating this equipment, please read these instructions completely and keep these operating instructions for future reference.

Introduction

Introduction

- Thank you for your purchase of the CR-60 Cornerounder®.
- We ask that you take a moment to fill in the serial number and other information on the front cover of this manual. Please keep this manual as a reference for future use.

Note: Only the Table Assemblies are serialized. Please keep records of all the Table Assemblies you may have purchased. The CR-60 arbor press does not contain a serial number itself.

- For parts and service please contact the Lassco-Wizer Dealer from whom you purchased the machine. If you require assistance in locating a Lassco-Wizer Dealer please contact our customer service department at 585-436-1934. Please have the model of your machine and the serial number when you call.
- If you wish to write to us please contact us at:

Lassco-Wizer
485 Hague Street
Rochester, NY 14606

Shipping Damage Inspection

- Remove the machine from the carton and inspect for any shipping damage. If any damage is present, report the damage to the carrier immediately. Failure to do so may void any warranties.

Introduction

Safety Instructions

- All operators must read and understand the Users Manual and all other safety instructions before using this equipment. Failure to fully understand the safety instructions can result in personal injury. If after reading the manual you are still uncertain about use, please contact the dealer from whom you purchased the machine for assistance. If you need contact information for a Service Technician nearest you please call 585-436-1934.
- Safety of this equipment is the responsibility of the users.
- This machine is designed for one person operation. Never operate the machine with more than one person.
- Do not place fingers under the Knives on the Table Assembly. Do not remove the safety guard on the Table Assembly.

Capacity

- **Commercial Grade Mild Steel**.....**0.035inch thick (0.89mm)**
- **Soft Aluminum**.....**0.080inch thick (2.03mm)**

Note: Exceeding the recommended capacity for this unit voids all warranties.

Note: Use of the Table Assembly without the use of the CR-60 arbor press voids all warranties.

Loose Item Inventory

- Remove and inspect the following items:

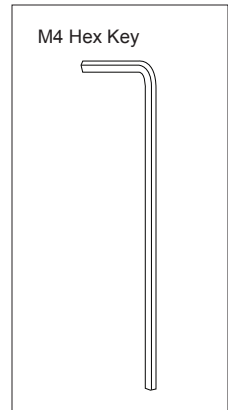
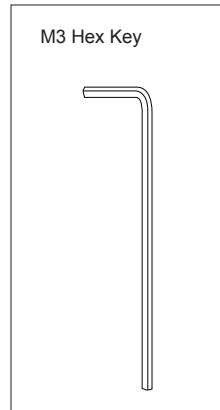
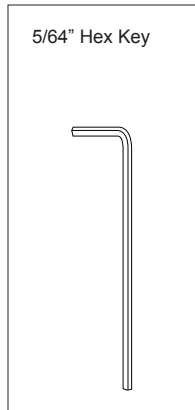
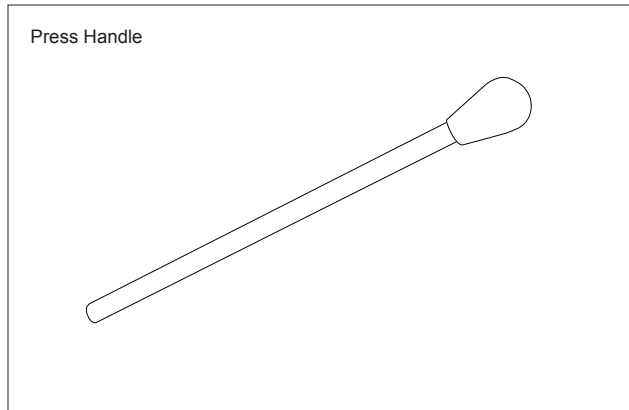

Items not to scale

Setting Up Your Machine

Attaching the Press Handle

- Insert the Press Handle into the hub of the press and tighten the setscrew onto the Press Handle with a M4 Hex Key until the Press Handle is secure.

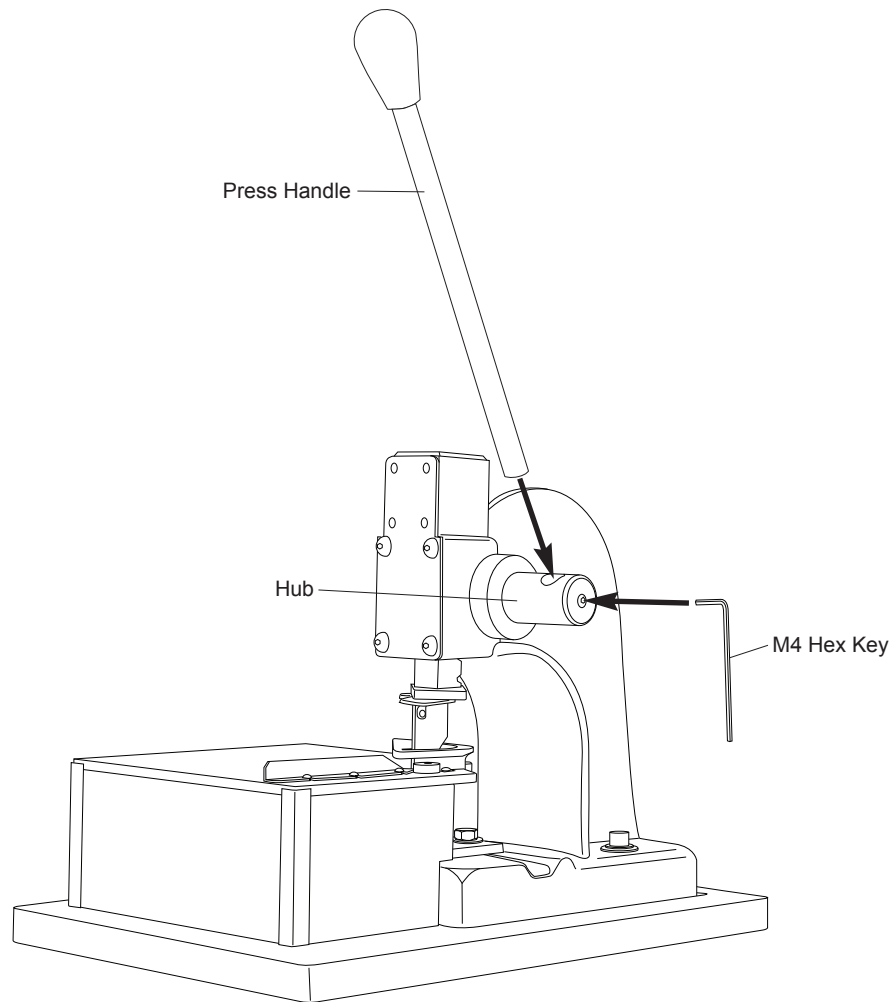

Operating Instructions

Rounding The Corners

■ To put a Radius on the corner of your product:

1. With the Press Handle in the up position as shown, slide the product to be cut along the guide until it comes to rest against the inside edge of the Outer Knife.
2. Hold the product in place firmly with one hand.

Note: Make sure to keep fingers away from the Knives.

3. Pull down on the handle so that the Outer Knife cuts through the product.

Note: A quick snapping motion near the end of the cut will improve the quality of the cut.

4. Raise the Press Handle to the up position and slide the product out from under the Outer Knife.

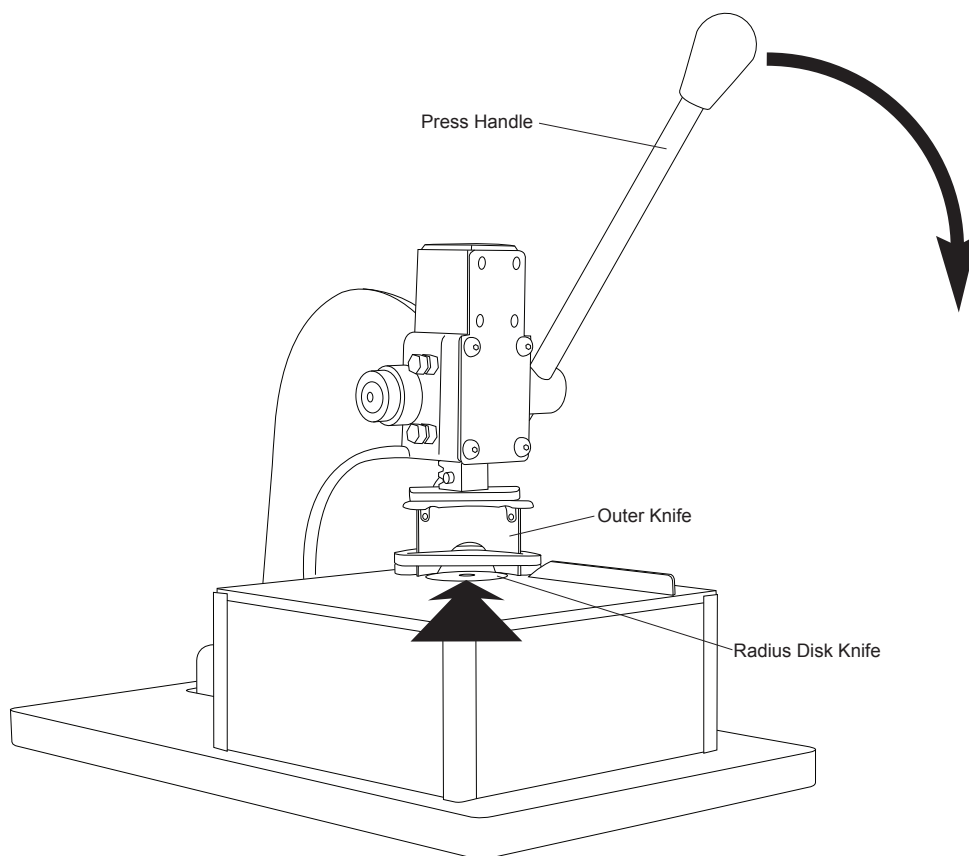

Note: Inspect the quality of the cut. The radius on the product should come to an almost perfect blend against the straight edges. The edges of the cut may have a small burr. This burr should not be excessive. If this burr is excessive, the Outer Knife may need adjusting, sharpening, or replacement. (See Page 06)

Note: Applying a small amount of light machine oil to your product before cutting and occasionally applying some light machine oil to the blade on the Table Assembly will prolong the life of the blade.

Operating Instructions

Changing The Table Assembly

■ To remove the Table Assembly...

1. Rotate the Press Handle to its full upright position so that the Chrome Knob is disengaged from the Rack Support Plate.
2. Using a 5/8" Wrench (not provided) loosen, but do not remove the 7/16"-20 x 1" Hex Head Table Mount Bolt.
3. Remove the Table Assembly from the Wooden Base.
4. Attach the new Table Assembly making sure the notch on the Bottom Plate fits into the 7/16"-20 x 1" Hex Head Table Mount Bolt. Make sure the 7/16" Flat Washer is on the topside of the Bottom Plate.
5. Tighten down the 7/16"-20 x 1" Hex Head Table Mount Bolt and pull down on the Press Handle to engage the Rack Support Plate. Make sure the Rack Support Plate is coming straight down onto the Chrome Knob. Adjust the Table Assembly as needed to obtain proper alignment with the Rack Support Plate.

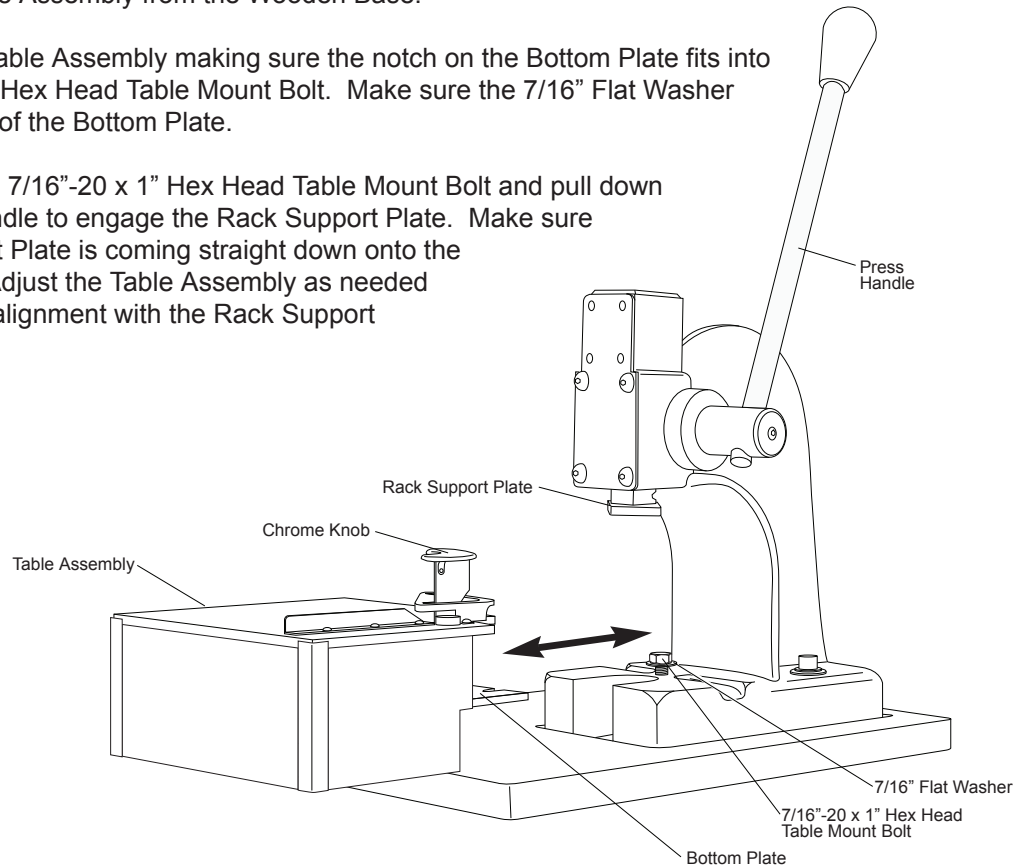

Note: When your machine is shipped, two Shipping Tabs are placed under the Table Assembly to help prevent movement and shipping damage. These tabs have no further function and can be removed if necessary.

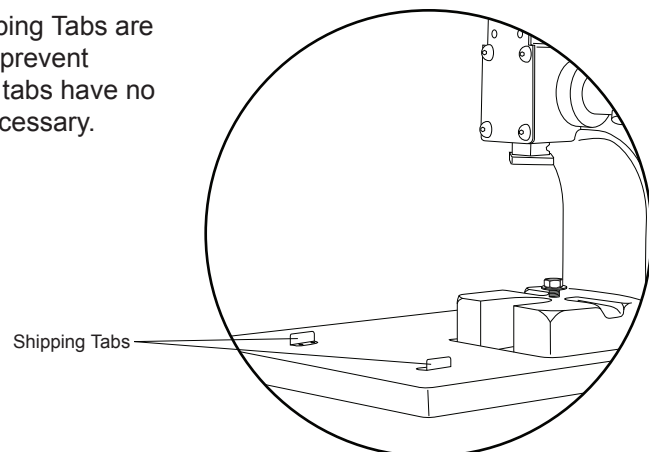

Maintenance

Adjusting the Outer Knife

- It is important to keep the Outer Knife in proper alignment or it can be pressed down at an incorrect angle causing unnecessary stress on the knife. This can cause the Outer Knife to dull quicker and/or break.

Note: Remove the Table Assembly from the CR-60 Arbor Press before adjusting the Outer Knife (See Page 05).

- The Outer Knife should be perpendicular (90°) to the surface of the Table Assembly. Loosen the Cam Adjustment Screws on the Cams using the 5/64" Hex Key provided. Rotate the Cams as needed so that they hold the Outer Knife in proper alignment.

Note: If the Cam is rotated too tight, the Outer Knife will stick in the down position when you attempt to operate.

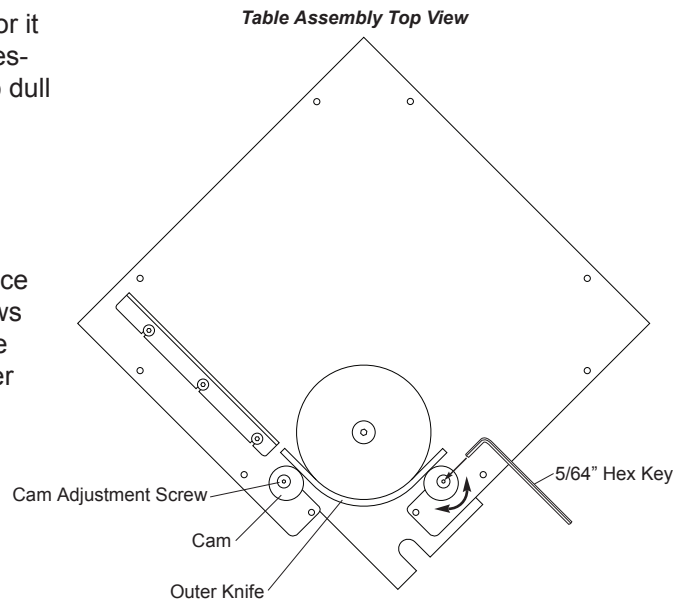

Replacing The Outer Knife

- Due to the fact that the Outer Knife is an expendable item, it will be necessary to replace it over time. Replace the Outer Knife if...

1. You have adjusted the Outer Knife alignment and it is still leaving an excessive burr.

Note: Sharpening service is available through Lassco-Wizer. Please contact us for further information.

2. Your Outer Knife has cracked or broken

- To replace the Outer Knife...

1. Remove the Table Assembly from the CR-60 Arbor Press (See Page 05).
2. Loosen the Cam Adjustment Screws and rotate the Cams so that they are not exerting pressure on the Outer Knife.
3. While pulling up on the Chrome Knob, press in the Knife Support Plate which should release the Outer Knife from the Casting.
4. Replace the new Outer Knife by inserting it into the Casting.
5. Press down on the Knife Support Plate until the Outer Knife snaps into position.
6. Adjust the Cams so that the Outer Knife is perpendicular to the surface of the Table Assembly.

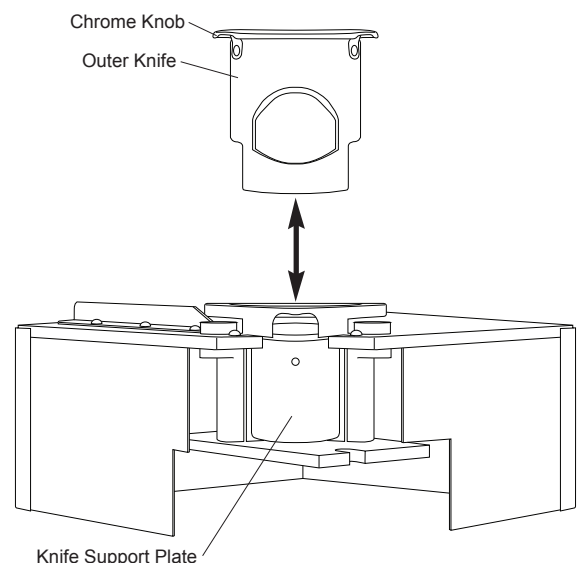
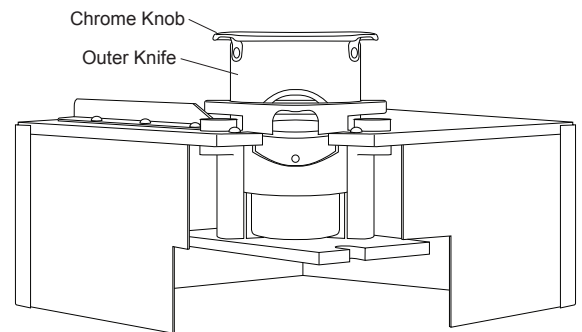

Trouble Shooting Guide

Problem	Cause	Correction
Excessive burrs appear on the edge of the product being cut.	Debris is wedged between the Outer Knife and the Disk Knife	Remove obstruction.
	Outer Knife is out of adjustment.	Adjust per the <i>Maintenance</i> portion of this manual.
	Outer Knife is dull.	Sharpen or replace the Outer Knife. (See <i>Maintenance</i>)
The Outer Knife does not return to the upright position during operation.	Debris is wedged between the Outer Knife and the Disk Knife	Remove obstruction.
	The Cams are adjusted too tight against the Outer Knife.	Loosen the Cam Adjustment Screws and rotate the Cams until they are properly adjusted. (See <i>Maintenance</i>)
	The Knife Return Springs are worn out.	Replace the Knife Return Springs. (Always replace both even though one may not be worn completely)

Parts Diagrams

CR-60 Arbor Press

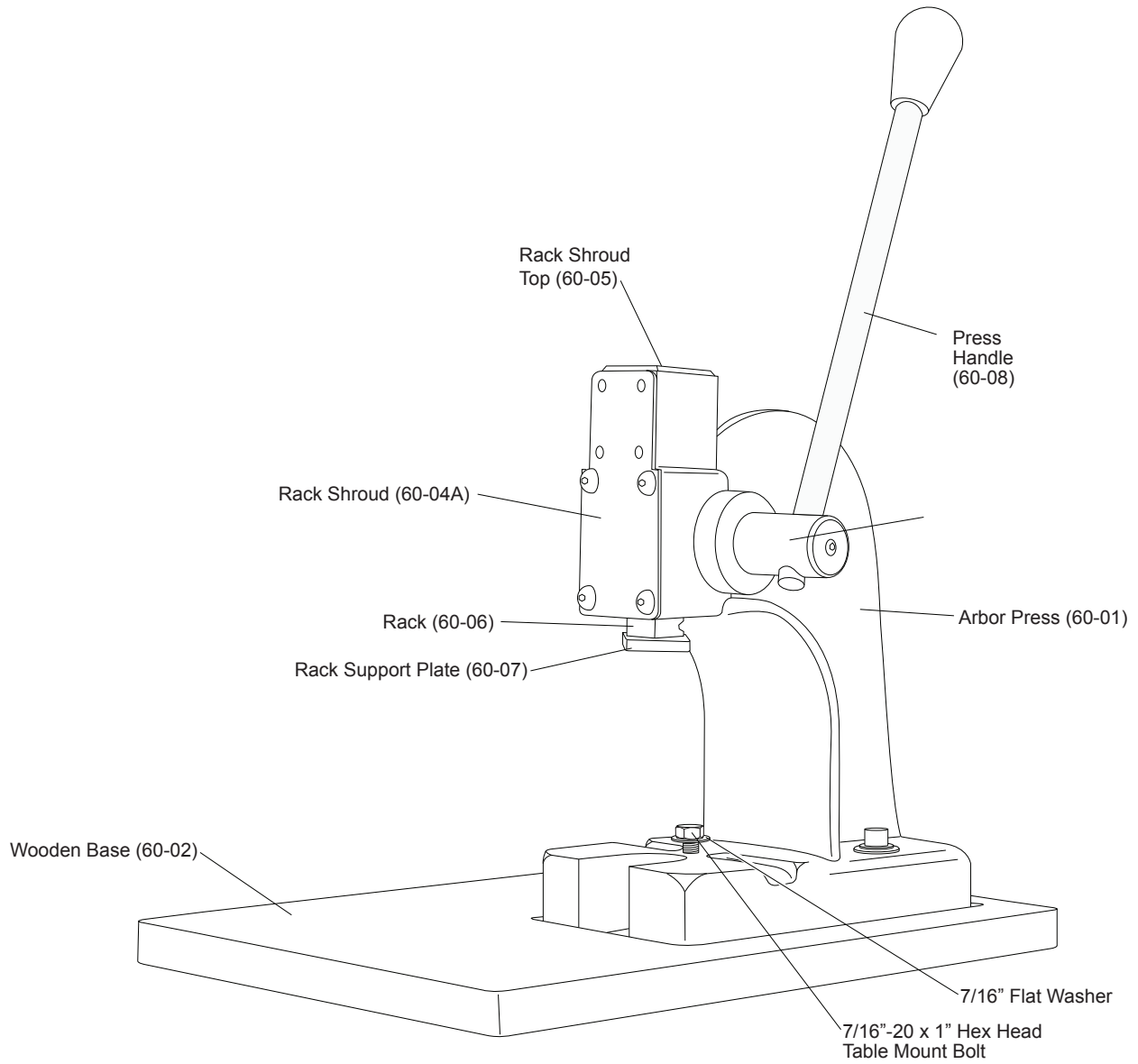

Parts Diagrams

Table Assembly

**Please note your Table Assembly may look slightly different depending on the size.*

■ Front View

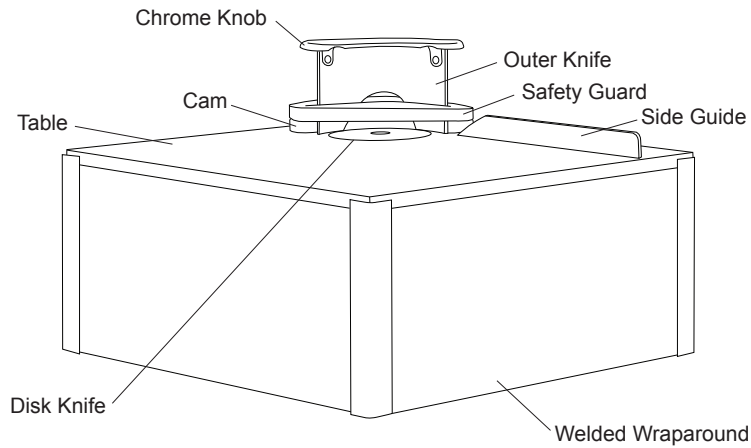

■ Top View

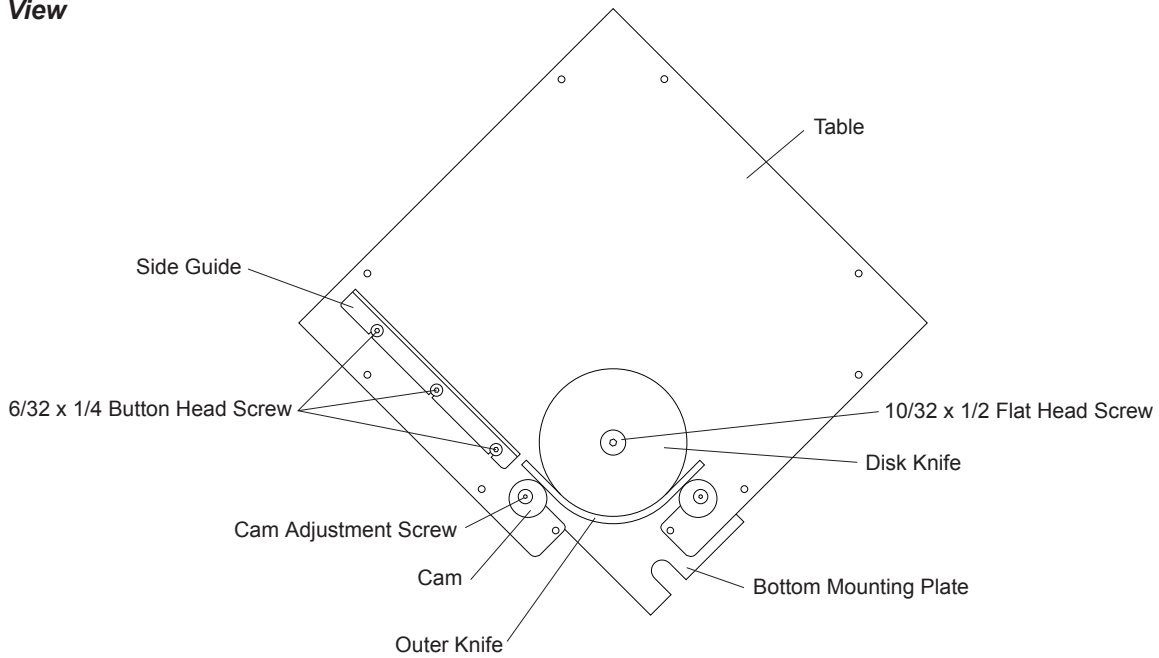

■ Rear View

