





**175 SP2(SC2)  
175 CP4(CC3)/CP5(CC4)/CP6(CC5)/CP7(CC6)**



000150

- Operating Manual 
- Operating instructions 
- Instructions d'opération 
- Instrucciones de uso 

---

# **intimus 175 SP2(SC2) + 175 CP4(CC3)/CP5(CC4)/CP6(CC5)/CP7(CC6)**

Typ/Type/Tipo:

**297-4S + 2 97-6S + 297-4C + 297-2C + 297-1C + 297-1CF**



**Before operating, please read the Operating Manual!**  
**Before operating, please read the Operating Instructions!**  
**Veillez lire le mode d'emploi avant la mise en service!**  
**Leer las instrucciones de uso antes de la puesta en servicio!**

---

**Operating Manual**  
**Operating Instructions**  
**Instructions d'opération**  
**Instrucciones de uso**

(page 3-10)

**USA**

(page 11-18)

**GB**

(page 19-26)

**F**

(página 27-34)

**E**

# Contents

<b>1</b>	<b>Safety Notes</b> .....	<b>3</b>	4.4	Motor protection .....	7
<b>2</b>	<b>Initiation</b> .....	<b>4</b>	4.5	Electrical fault .....	8
2.1	Scope of application .....	4	4.6	Fault check list .....	8
2.2	Installation .....	4	<b>5</b>	<b>Maintenance / Disposing</b> .....	<b>8</b>
<b>3</b>	<b>Operation</b> .....	<b>4</b>	5.1	Cutter maintenance (machines without automatic oil system) .....	8
3.1	Controls .....	4	5.2	Cutter maintenance (machines with automatic oil system) .....	8
3.2	Switching the machine on .....	5	5.3	Cleaning the photocells .....	9
3.3	Material feed .....	6	5.4	Automatic energy saving .....	9
3.4	Emptying the receptacle .....	6	5.5	Disposing of the machine .....	9
3.5	Dynamic load display .....	6	<b>6</b>	<b>Technical Data</b> .....	<b>10</b>
3.6	Customization of automatic oiler output ....	7	<b>7</b>	<b>Accessories</b> .....	<b>10</b>
<b>4</b>	<b>Malfunctions</b> .....	<b>7</b>	<b>8</b>	<b>Certificate of Conformity</b> .....	<b>35</b>
4.1	Material jam in the machine .....	7			
4.2	Light barrier covered when door opened ...	7			
4.3	Light barrier covered when machine turned on .....	7			

## 1 Safety Notes



### DANGER!

#### Danger of injury! Damage to the machine!

- ☞ The air vents in the housing are necessary for cooling and may not be covered or closed!
- ☞ The mains connection at the machine must be freely accessible!
- ☞ Only operate the machine in enclosed rooms at temperatures between 10°C and 25°C!
- ☞ Always close the open housing door slowly to prevent any damage to the electronics.



#### The machine may not be operated by more than one person at any given time!

The machine was designed for safe operation by "one person only".



#### During the shredding process no other work may be performed on the machine (for example cleaning, etc.)!



#### The machine is not a toy, and is not suitable for use by children!

The overall technical safety concept of this machine (dimensions, feed openings, emergency shutdown devices etc.) does not provide for any guarantee regarding hazard-free operation by children.



#### Danger of injury! Keep all loose articles of clothing, ties, jewelry, long hair or other loose objects away from opening!



#### Danger of injury! Never insert fingers into opening!



#### In case of danger switch the machine off with the mains switch, or with the emergency switch, or unplug the machine!



#### Always unplug the machine from the mains power supply before opening the machine!

Repairs may only be performed by trained personnel!

## 2 Initiation

### 2.1 Scope of application



#### CAUTION!

**Damage to the cutting mechanism!**  
**The machine must only be used to shred paper!**

Shredding of other types of data carriers and also of staples and paper clips with the models with cutting width 0.03x0.47 in. (CP6/CC5) or 0.03x0.18 in. (CP7/CC6) may lead to injuries (for example due to splintering of hard materials etc.) and damage to the machine (for example destruction of the cutter etc.).

**Exception:** Single CD's or 3.5" computer diskettes can also be shredded with **0.15 in., 0.23 in., 0.16x1.57 in., 0.07x0.59 in.** models.

The document shredder **intimus 175SP2(SC2)/CP4(CC3)/CP5(CC4)/CP6(CC5)/CP7(CC6)** is a machine for the destruction of common written material.

### 2.2 Installation

1. Unpack and set machine upright.
2. Place plastic sack into the receptacle.
3. Machines with automatic oil system: For oiler installation remove the screw (fig. 1/2) from the oil hose (fig. 1/1).

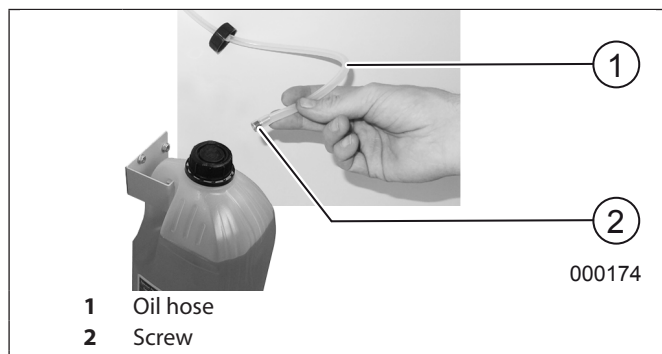
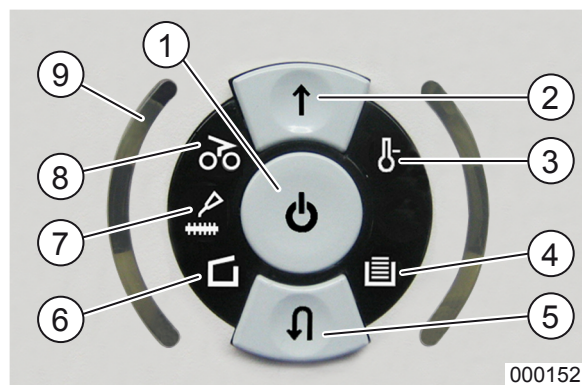

fig.1 Oiler installation

4. Connect the machine to the power with the plug. (For information on the right fuse for the plug see „Technical Data“, p. 18).

## 3 Operation

### 3.1 Controls



- 1 Functions button
- 2 Forwards button
- 3 Control display „Motor overload“ / „Electrical fault“
- 4 Control display „Collection bin full“
- 5 Reverse button „Stop“ / „Reverse“
- 6 Control display „Door open“ / „Door malfunction“
- 7 Control display „Oil cutters“ / „To change the oil container“
- 8 Control display „Material jam“
- 9 Control display „Load level of the motor“

fig.2 Controls „i-control“

#### ① = Functions button (fig. 2/1)

##### a) „Ready“

The machine changes to “Ready” if you press this button briefly. At the same time the integral LED display comes on.

##### b) „Off“

The machine switches off if it is in the “Ready” mode and the button is held down for about 3 seconds.

#### ! NOTE!

The machine switches off automatically if it is not used for about 15 minutes.

##### c) „Stop“

If you press this button briefly when the cutters are running they switch off and stop.

#### ② = Forwards button (fig. 2/2)

If this button is pressed, the cutting mechanism runs forwards for a few seconds, e.g. to remove remaining material from the cutting mechanism. At the same time the integrated LED display lights up.

By pressing and holding this button when the motor has stopped, the cutting mechanism runs forwards.

**③ = Control display (fig. 2/3) „Motor overload“ / „Electrical fault“**

To find out what to do see the relevant description under the section „Malfunctions“, p. 15.

**a) „Motor overload“**

Comes on when the motor has been overloaded and has switched off. The machine cannot be started while the motor is cooling down.

**b) „Electrical fault“**

**Flashes** when there is an electrical fault inside the control board. The machine switches off. Please contact your dealer.

**④ = Control display (fig. 2/4) „Collection bin full“**

Lit when the collection bin is full and needs to be emptied. The cutter is switched off.

**⑤ = Reverse button (fig. 2/5)**
**a) „Stop“**

If you press this button briefly when the cutters are running they switch off and stop.

**b) „Reverse“**

By pressing and holding this button when the motor has stopped, the cutting mechanism runs in reverse. The integrated LED indicator  lights up at the same time.

**⑥ = Control display (fig. 2/6)**
**a) „Door open“**

Comes on if the door on the lower part of the machine is opened. The motor switches off automatically and cannot be started as long as the door remains open.

**b) „Door malfunction“**

**Flashes** when there is an electrical fault in the door sensor. The motor switches off. Please contact your dealer.

**⑦ = Control display (fig. 2/7)**
**a) „Oil cutters“ (Machines without automatic oil system)**

Comes on when the cutters in the cross cut version must be oiled. The lubrication procedure must be acknowledged on the reverse button (fig. 2/5) (see description in „Cutter maintenance (machines without automatic oil system)“, p. 16).

**b) „To change the oil container“ (Machines with automatic oil system)**

The control display flashes when the oil container is empty and must be replaced with a full container. The motor is switched off. The oil container change must be acknowledged on the reverse button (see „Cutter maintenance (machines with automatic oil system)“, p. 16).

**! NOTE!**

The motor is switched off when this display flashes. The motor can only be restarted when the empty oil container has been replaced with a full container.

**⑧ = Control display (fig. 2/8)**

For the procedures see the relevant description under the section „Malfunctions“, p. 15.

**a) „Material jam in machine“**

Comes on when too much material has been fed into the cutters. The cutters jam, then run in reverse for a short time and stop. The motor switches off.

**b) „Light barrier covered when door open“**

Comes on when there is still material in the feed slot when the door is opened. The cutters stop. The motor switches off.

**c) „Light barrier covered when machine turned on“**

Comes on when there is still material in the feed slot when the machine is switched on.

**⑨ = Control display (fig. 2/9) „Load level of the motor“**

Displays the current load level of the motor during the shredding process via different colour lights (see description under „Dynamic load display“, p. 14).



**Light barrier**



fig. 3 Light barrier

The shredding procedure starts as soon as material is fed into the feed slot.

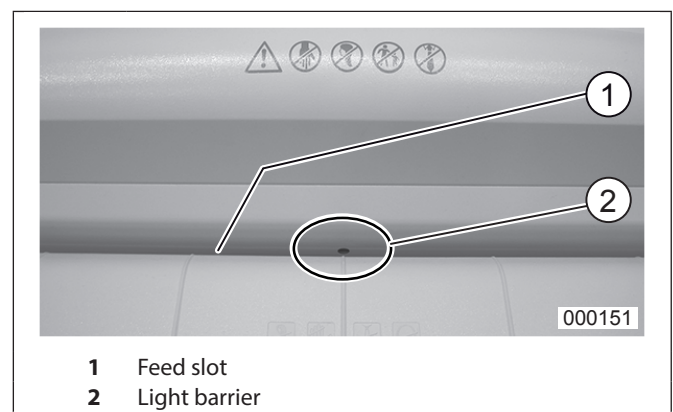
At the same time the integral forward button LED display  comes on.

### 3.2 Switching the machine on

Press the function button (fig. 2/1) briefly.

- The function button LED display  comes on for „Ready“.
- The machine can be loaded.



### 3.3 Material feed



#### CAUTION!

##### Damage to the machine!

- △ Never feed the shredder with a quantity of material exceeding the maximum indicated. Refer to „*Technical Data*“, p. 18!
- △ Should the machine become overloaded, follow the instructions under „*Material jam in the machine*“, p. 15.

Feed paper to the cutting mechanism through the feed slot (fig. 3/1).

- Machine switches automatically to forward and draws paper in.
- The motor switches off automatically after shredding.



#### NOTE!

For shredding transparent films, the machine must be manually switched to forwards running (press and hold the forwards button (fig. 2/2)).

If the machine is not used for a period of approx. 15 mins., it automatically switches off.

### 3.4 Emptying the receptacle

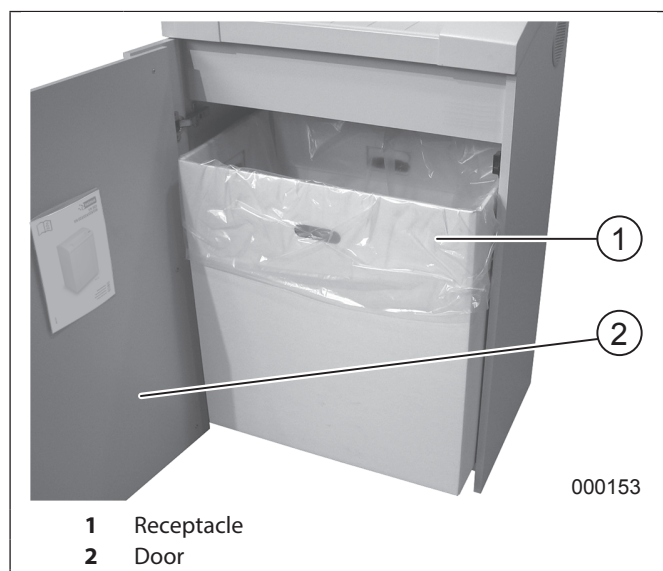

fig.4 Receptacle

The motor switches off if the receptacle is full. The control display ☐ (fig. 2/4) comes on.



#### NOTE!

To complete the shredding process when the motor is switched off, press and hold the forward button (fig. 2/2).

- The cutting mechanism continues to run forward for approx. four seconds.

This process can only be activated once.

Empty the receptacle as follows:

1. Open the door (fig. 4/2).
  - The control display ☐ (fig. 2/6) comes on.
  - If there is still material in the feed slot, the control display ☐ (fig. 2/8) also comes on.
2. Remove the bag and dispose of the contents.
  - The control display ☐ (fig. 2/4) goes out.
3. Place empty sack into receptacle.
4. Close the door.
  - The control display ☐ (fig. 2/6) goes out.
5. If the control display ☐ comes on, press the forward button (fig. 2/2) briefly. The remaining material in the feed slot is shredded and the display goes out.



#### NOTE!

The machine will only run if the door is closed!

### 3.5 Dynamic load display

During the shredding process, an LED control indicator (fig. 2/9) displays the extent of the load on the motor:

- Green light: load < 75 %
- Red light: load 75 - 100 %

The control display should remain on green to avoid a material jam!



#### NOTE!

The load display system calibrates automatically! By that the load display can differ (e.g. at idle speed the control display comes on in red). That is no quality deficit. After several shredding processes the load display normalizes.

### 3.6 Customization of automatic oiler output

The automatic oiler output can be adapted to your requirements:

- a) Ample Mode:** 25% more oil is transported to the cutting mechanism than in normal mode.
- b) Normal Mode - default setting**
- c) Scarce Mode:** 25% less oil is transported to the cutting mechanism than in normal mode.

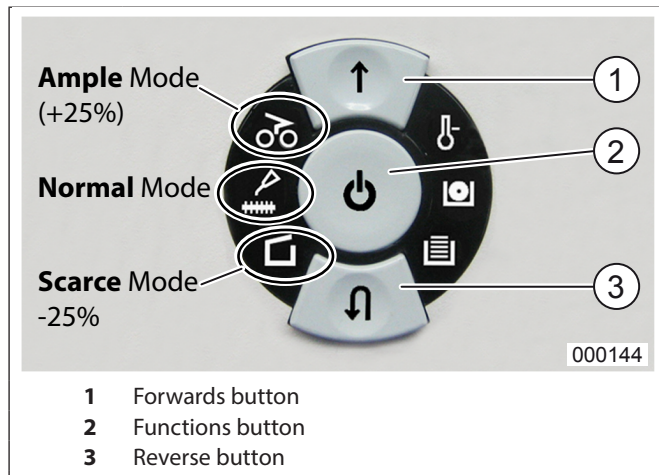

fig.5 Customization of automatic oiler output

For customizing the automatic oiler output proceed as follows:



1. The machine must be switched off.
2. Open the door.
3. Press and hold the forward button (fig. 5/1) and the reverse button (fig. 5/3) simultaneously.
4. Additionally press and let go of the function button (fig. 5/2).
  - All LED indicators on the display light up.
5. Let go of the forward button and the reverse button.
  - Now you are in the memory mode.
6. Press the forward button **twice** (fig. 5/1).
  - Now you are in the customization mode for automatic oiler output.
  - The LED indicator on the left side flashes showing the current settings.
7. Press the function button (fig. 5/2) so often until the needed oiler output mode comes on.
  - Each time you press the function button the output mode changes (Ample, Scarce, Normal)
8. Press the reverse button (fig. 5/3).
  - Now you are again in the memory mode.
9. Press the function button.
  - The selected settings are saved.
  - The machine switches off.
10. Close the door.

If you want to continue shredding turn the machine on: press the function button (fig. 5/2) briefly.

## 4 Malfunctions

### 4.1 Material jam in the machine (auto-reverse-funktion)

If a jam is caused by too much material being fed in the following happens:

- The cutters jam, then run in reverse for a short time (material is released) and stop.
- The motor switches off.
- The control display  (fig. 2/8) comes on. Proceed as follows:
  1. Remove any returned paper or briefly press the forward button (fig. 2/2).
    - The cutters now run forwards automatically and shred the remaining paper in the cutters. During the forward run the forward button (fig. 2/2) LED display  comes on. The control display  (fig. 2/8) goes out.
  2. Continue shredding with less paper.

### 4.2 Light barrier covered when door opened

Should there still be material in the feed slot when the door is opened, the motor switches off and the cutters stop. The control display  (fig. 2/8) comes on.

Close the door and acknowledge the status by pressing the forward button (fig. 2/2) briefly. The existing material is fed to the cutters and shredded.

### 4.3 Light barrier covered when machine turned on



Should there still be material in the feed slot when the machine is switched on the control display  (fig. 2/8) comes on.

1. Remove the material or
2. Press the forward button (fig. 2/2) briefly.
  - The existing material is fed to the cutters and shredded.

### 4.4 Motor protection

Should the motor be overloaded it switches off. The control display  (fig. 2/3) comes on. The machine can be started again after a cooling down period of about 15 – 20 minutes (depending on the model and the room temperature).

## 4.5 Electrical fault

If the function button (fig. 2/1) LED display  flashes or only the control display  (fig. 2/6) flashes there is an electrical fault.

1. Switch off the machine once.
2. Turn the machine on again.
  - This helps in many cases.

If the machine still fails to start up, please notify your dealer.

## 4.6 Fault check list

Should the machine not work, check the following points:

- is the plug connected to the power supply?
- is the door closed?
- is the receptacle full?
  - Follow the instructions under „Emptying the receptacle“, p. 14.
- Is there a material jam in the machine?
  - Follow the instructions in „Material jam in the machine“, p. 15.
- Is the motor overloaded?
  - See „Motor protection“, p. 15.

### NOTE!

In many cases, restarting the machine helps:

1. Switch off the machine once.
2. Turn the machine on again.

If none of these test points apply, please contact your dealer.

## 5 Maintenance / Disposing





### 5.1 Cutter maintenance (machines without automatic oil system)

Cross cut cutters must be oiled after 30 min operating time. If the control display  (fig. 2/7) comes on proceed as follows:

Spread some of the special oil provided on a sheet of paper and then feed this into the cutter via the feed slot.

The paper is drawn in and at the same time the cutter is supplied with oil for the necessary lubrication.

This procedure is acknowledged as follows to turn off the display after the cutters have been oiled:

1. Open the door until the control display  (fig. 2/6) lights up.
  - The control displays  and  flash.
2. Press the reverse button  (fig. 2/5) and keep it held down until the control display  goes out.
3. Close the door again.

The cutters now start a greasing cycle automatically (forward and reverse run) and then switch off. The machine is ready for use again. Should you need to re-order the special oil see „Accessories“, p. 18.

### 5.2 Cutter maintenance (machines with automatic oil system)

Cross-cut cutting mechanisms must be oiled regularly after a certain period of operation. This is done automatically by the integrated oiler.

If the control display  (fig. 2/7) flashes, this usually means that the oil container (fig. 6/3) is empty and must be replaced with a full container. The motor switches off.

### NOTE!

To complete the shredding process when the motor is switched off, press and hold the forward button (fig. 2/2).

- The cutting mechanism continues to run forward for approx. four seconds.

This process can only be activated once.

#### Changing the oil container:

1. Open the door.
  - The control display  (fig. 2/6) comes on.
  - The control display for the reverse button (fig. 2/5) and oil sensor (fig. 2/7) flashes.



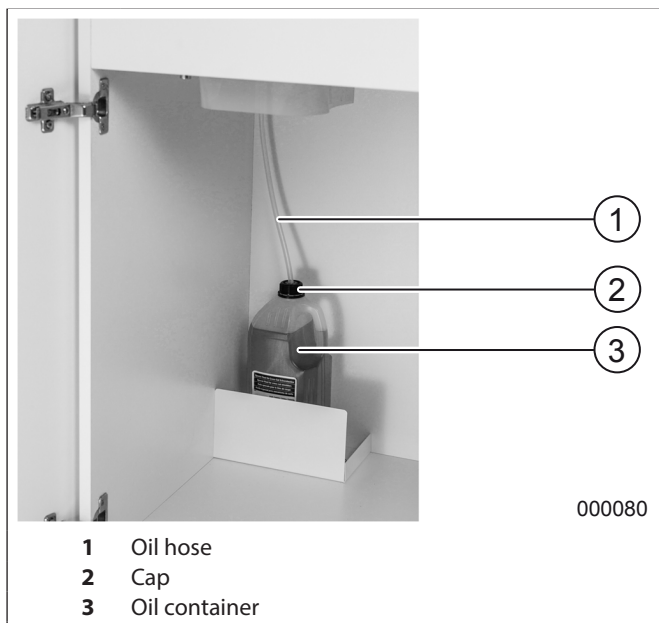



fig.6 Oil container

2. Release the screw cap (fig.6/2), take the oil hose with the screw cap out of the empty container and remove the container.
3. Suspend the full container and remove the screw cap. Feed the oil hose (fig.6/1) into the container and close the container again with the screw cap that is connected to the oil hose.
4. Press the reverse button (fig.2/5).
  - The control display  (fig.2/5) goes out.
5. Close the door.
  - The control display  (fig.2/6) goes out.
  - The control display (fig.2/7) goes out.

The machine is ready for use again. Should you need to re-order the special oil see „Accessories“, p. 18.

### 5.3 Cleaning the photocells



fig.7 Cleaning the photocells

If paper particles should come to rest in the inlet guide (for example after a paper jam) it is possible that the machine will not turn off, due to the broken light barrier.

To remove these paper strips and also to clean the photocell, pass another sheet of paper through the feed slot, or switch the machine off and wipe both “eyes” of the photocell with a brush (fig.7).

### 5.4 Automatic energy saving

If the machine is not used for a while it automatically switches off after about 15 minutes. The function button (fig.2/1) LED display  for “Ready” goes out. Press the function button briefly to turn it on again.

### 5.5 Disposing of the machine



Dispose of the machine in an environmentally friendly fashion at the end of its useful service life. Do not dispose of any of the parts included in the machine or its packaging with household waste.

## 6 Technical Data

Cutting size	
175SP2(SC2):	0.15 in. (stripes) 0.23 in. (stripes)
175CP4(CC3):	0.16x1.57 in. (cross-cut)
175CP5(CC4):	0.07x0.59 in. (cross-cut)
175CP6(CC5):	0.03x0.47 in. (cross-cut)
175CP7(CC6):	0.03x0.18 in. (cross-cut)
Cutting speed	
175SP2(SC2):	4.72 in./sec.
175CP4(CC3)/CP5(CC4):	5.12 in./sec.
175CP6(CC5):	5.90 in./sec.
175CP7(CC6):	9.05 in./sec.
Cutting capacity	
175SP2(SC2) 3,8 mm	40-45 sheets (70g/m <sup>2</sup> )
175SP2(SC2) 5,8 mm	65-70 sheets (70g/m <sup>2</sup> )
175CP4(CC3):	40-50 sheets (70g/m <sup>2</sup> )
175CP5(CC4):	25-30 sheets (70g/m <sup>2</sup> )
175CP6(CC5):	15-17 sheets (70g/m <sup>2</sup> )
175CP7(CC6):	8-10 sheets (70g/m <sup>2</sup> )
Supply voltage:	
	230 V/50 Hz, 120 V/60 Hz
Pre-fusing (slow-blow):	
	230 V/50 Hz = 16 amps 120 V/60 Hz = 20 amps
Working width:	
	15.94 in.
Noise level:	
	approx. 52 dB (A)
Power:	
	1,1 kW
Dimensions (WxDxH):	
	25.98x22.05x41.34 in.
Weight:	
	approx. 90 kg

## 7 Accessories

Description	Order-No.
Plastic bag, 23.62 x 19.68 x 39.37 x 0,002 in.	99952
Lubricant, 110 ml bottle	88035
Oil container, 2000 ml	91869



### NOTE!

For orders of accessories and spare parts please contact your dealer.

# Contents

<b>1</b>	<b>Safety Notes</b> .....	<b>11</b>	4.4	Motor protection	.....	15
<b>2</b>	<b>Initiation</b> .....	<b>12</b>	4.5	Electrical fault	.....	16
2.1	Scope of application	.....	4.6	Fault check list	.....	16
2.2	Installation	.....	<b>5</b>	<b>Maintenance / Disposing</b>	.....	<b>16</b>
<b>3</b>	<b>Operation</b> .....	<b>12</b>	5.1	Cutter maintenance (machines without automatic oil system)	.....	16
3.1	Controls	.....	5.2	Cutter maintenance (machines with automatic oil system)	.....	16
3.2	Switching the machine on	.....	5.3	Cleaning the photocells	.....	17
3.2	Switching the machine on	.....	5.4	Automatic energy saving	.....	17
3.4	Emptying the receptacle	.....	5.5	Disposing of the machine	.....	17
3.5	Dynamic load display	.....	<b>6</b>	<b>Technical Data</b>	.....	<b>18</b>
3.6	Customization of automatic oiler output	... 15	<b>7</b>	<b>Accessories</b>	.....	<b>18</b>
<b>4</b>	<b>Malfunctions</b> .....	<b>15</b>	<b>8</b>	<b>Certificate of Conformity</b>	.....	<b>35</b>
4.1	Material jam in the machine	.....				
4.2	Light barrier covered when door opened	.. 15				
4.3	Light barrier covered when machine turned on	.....				

## 1 Safety Notes



### DANGER!

#### Danger of injury! Damage to the machine!

- ☞ The air vents in the housing are necessary for cooling and may not be covered or closed!
- ☞ The mains connection at the machine must be freely accessible!
- ☞ Only operate the machine in enclosed rooms at temperatures between 10°C and 25°C!
- ☞ Always close the open housing door slowly to prevent any damage to the electronics.



#### The machine may not be operated by more than one person at any given time!

The machine was designed for safe operation by "one person only".



#### During the shredding process no other work may be performed on the machine (for example cleaning, etc.)!



#### The machine is not a toy, and is not suitable for use by children!

The overall technical safety concept of this machine (dimensions, feed openings, emergency shutdown devices etc.) does not provide for any guarantee regarding hazard-free operation by children.



#### Danger of injury! Keep all loose articles of clothing, ties, jewelry, long hair or other loose objects away from opening!



#### Danger of injury! Never insert fingers into opening!



#### In case of danger switch the machine off with the mains switch, or with the emergency switch, or unplug the machine!



#### Always unplug the machine from the mains power supply before opening the machine!

Repairs may only be performed by trained personnel!

## 2 Initiation

### 2.1 Scope of application



#### CAUTION!

**Damage to the cutting mechanism!**  
**The machine must only be used to shred paper!**

Shredding of other types of data carriers and also of staples and paper clips with the models with cutting width 0.8x12 mm (CP6/CC5) or 0.8x4.5 mm (CP7/CC6) may lead to injuries (for example due to splintering of hard materials etc.) and damage to the machine (for example destruction of the cutter etc.).

**Exception:** Single CD's or 3.5" computer diskettes can also be shredded with **3.8mm, 5.8mm, 4x40mm, 1.9x15mm** models.

The document shredder **intimus 175SP2(SC2)/CP4(CC3)/CP5(CC4)/CP6(CC5)/CP7(CC6)** is a machine for the destruction of common written material.

### 2.2 Installation

1. Unpack and set machine upright.
2. Place plastic sack into the receptacle.
3. Machines with automatic oil system: For oiler installation remove the screw (fig. 1/2) from the oil hose (fig. 1/1).

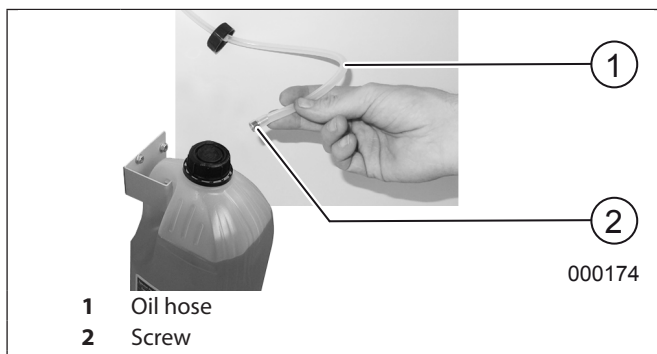
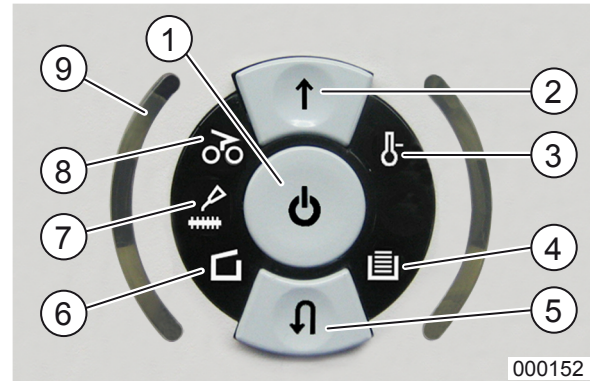

fig.1 Oiler installation

4. Connect the machine to the power with the plug. (For information on the right fuse for the plug see „Technical Data“, p. 18).

## 3 Operation

### 3.1 Controls



- 1 Functions button
- 2 Forwards button
- 3 Control display „Motor overload“ / „Electrical fault“
- 4 Control display „Collection bin full“
- 5 Reverse button „Stop“ / „Reverse“
- 6 Control display „Door open“ / „Door malfunction“
- 7 Control display „Oil cutters“ / „To change the oil container“
- 8 Control display „Material jam“
- 9 Control display „Load level of the motor“

fig.2 Controls „i-control“

#### ① = Functions button (fig. 2/1)

##### a) „Ready“

The machine changes to „Ready“ if you press this button briefly. At the same time the integral LED display  comes on.

##### b) „Off“

The machine switches off if it is in the „Ready“ mode and the button is held down for about 3 seconds.

#### ! NOTE!

The machine switches off automatically if it is not used for about 15 minutes.

##### c) „Stop“

If you press this button briefly when the cutters are running they switch off and stop.

#### ② = Forwards button (fig. 2/2)

If this button is pressed, the cutting mechanism runs forwards for a few seconds, e.g. to remove remaining material from the cutting mechanism. At the same time the integrated LED display  lights up.

By pressing and holding this button when the motor has stopped, the cutting mechanism runs forwards.

**③ = Control display (fig. 2/3) „Motor overload“ / „Electrical fault“**

To find out what to do see the relevant description under the section „Malfunctions“, p. 15.

**a) „Motor overload“**

Comes on when the motor has been overloaded and has switched off. The machine cannot be started while the motor is cooling down.

**b) „Electrical fault“**

**Flashes** when there is an electrical fault inside the control board. The machine switches off. Please contact your dealer.

**④ = Control display (fig. 2/4) „Collection bin full“**

Lit when the collection bin is full and needs to be emptied. The cutter is switched off.

**⑤ = Reverse button (fig. 2/5)**
**a) „Stop“**

If you press this button briefly when the cutters are running they switch off and stop.

**b) „Reverse“**

By pressing and holding this button when the motor has stopped, the cutting mechanism runs in reverse. The integrated LED indicator  lights up at the same time.

**⑥ = Control display (fig. 2/6)**
**a) „Door open“**

Comes on if the door on the lower part of the machine is opened. The motor switches off automatically and cannot be started as long as the door remains open.

**b) „Door malfunction“**

**Flashes** when there is an electrical fault in the door sensor. The motor switches off. Please contact your dealer.

**⑦ = Control display (fig. 2/7)**
**a) „Oil cutters“ (Machines without automatic oil system)**

Comes on when the cutters in the cross cut version must be oiled. The lubrication procedure must be acknowledged on the reverse button (fig. 2/5) (see description in „Cutter maintenance (machines without automatic oil system)“, p. 16).

**b) „To change the oil container“ (Machines with automatic oil system)**

The control display flashes when the oil container is empty and must be replaced with a full container. The motor is switched off. The oil container change must be acknowledged on the reverse button (see „Cutter maintenance (machines with automatic oil system)“, p. 16).

**! NOTE!**

The motor is switched off when this display flashes. The motor can only be restarted when the empty oil container has been replaced with a full container.

**⑧ = Control display (fig. 2/8)**

For the procedures see the relevant description under the section „Malfunctions“, p. 15.

**a) „Material jam in machine“**

Comes on when too much material has been fed into the cutters. The cutters jam, then run in reverse for a short time and stop. The motor switches off.

**b) „Light barrier covered when door open“**

Comes on when there is still material in the feed slot when the door is opened. The cutters stop. The motor switches off.

**c) „Light barrier covered when machine turned on“**

Comes on when there is still material in the feed slot when the machine is switched on.

**⑨ = Control display (fig. 2/9) „Load level of the motor“**

Displays the current load level of the motor during the shredding process via different colour lights (see description under „Dynamic load display“, p. 14).



**Light barrier**



fig. 3 Light barrier

The shredding procedure starts as soon as material is fed into the feed slot.

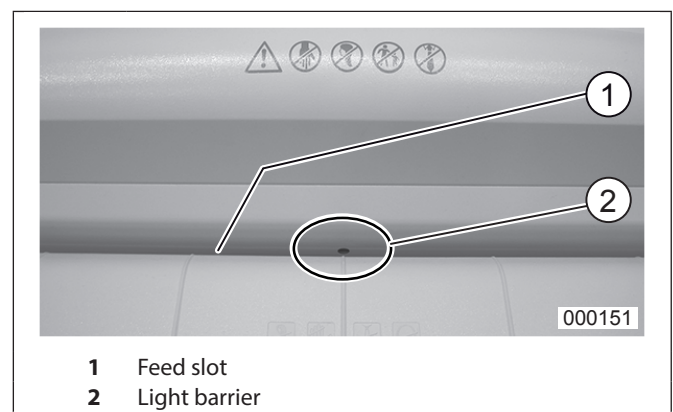
At the same time the integral forward button LED display  comes on.

## 3.2 Switching the machine on

Press the function button (fig. 2/1) briefly.

- The function button LED display  comes on for “Ready”.
- The machine can be loaded.



### 3.3 Material feed



#### CAUTION!

##### Damage to the machine!

- △ Never feed the shredder with a quantity of material exceeding the maximum indicated. Refer to „*Technical Data*“, p. 18!
- △ Should the machine become overloaded, follow the instructions under „*Material jam in the machine*“, p. 15.

Feed paper to the cutting mechanism through the feed slot (fig. 3/1).

- Machine switches automatically to forward and draws paper in.
- The motor switches off automatically after shredding.



#### NOTE!

For shredding transparent films, the machine must be manually switched to forwards running (press and hold the forwards button (fig. 2/2)).

If the machine is not used for a period of approx. 15 mins., it automatically switches off.

### 3.4 Emptying the receptacle

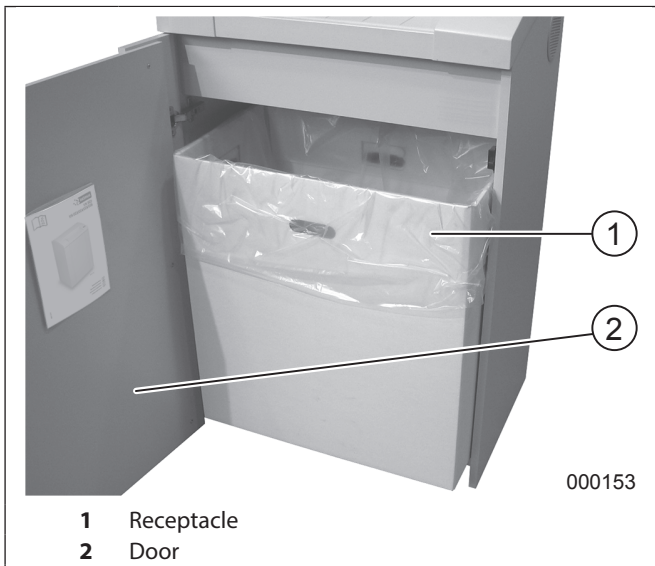

- 1 Receptacle
- 2 Door

fig.4 Receptacle

The motor switches off if the receptacle is full. The control display (fig. 2/4) comes on.



#### NOTE!

To complete the shredding process when the motor is switched off, press and hold the forward button (fig. 2/2).

- The cutting mechanism continues to run forward for approx. four seconds.

This process can only be activated once.

Empty the receptacle as follows:

1. Open the door (fig. 4/2).
  - The control display (fig. 4/6) comes on.
  - If there is still material in the feed slot, the control display (fig. 2/8) also comes on.
2. Remove the bag and dispose of the contents.
  - The control display (fig. 2/4) goes out.
3. Place empty sack into receptacle.
4. Close the door.
  - The control display (fig. 2/6) goes out.
5. If the control display comes on, press the forward button (fig. 2/2) briefly. The remaining material in the feed slot is shredded and the display goes out.



#### NOTE!

The machine will only run if the door is closed!

### 3.5 Dynamic load display

During the shredding process, an LED control indicator (fig. 2/9) displays the extent of the load on the motor:

- Green light: load < 75 %
- Red light: load 75 - 100 %

The control display should remain on green to avoid a material jam!



#### NOTE!

The load display system calibrates automatically! By that the load display can differ (e.g. at idle speed the control display comes on in red). That is no quality deficit. After several shredding processes the load display normalizes.

### 3.6 Customization of automatic oiler output

The automatic oiler output can be adapted to your requirements:

- a) Ample Mode:** 25% more oil is transported to the cutting mechanism than in normal mode.
- b) Normal Mode - default setting**
- c) Scarce Mode:** 25% less oil is transported to the cutting mechanism than in normal mode.

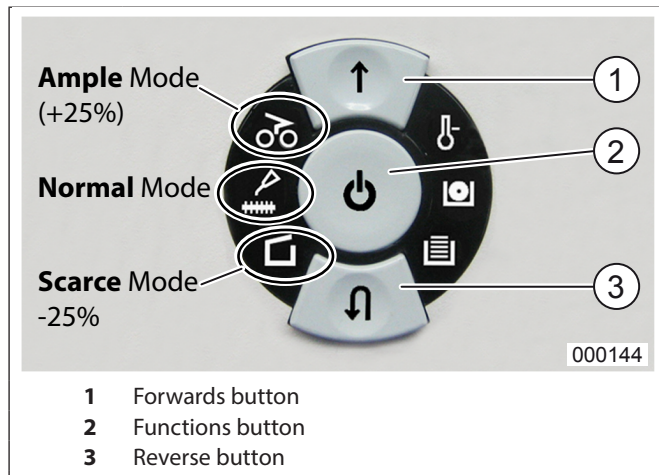

fig.5 Customization of automatic oiler output

For customizing the automatic oiler output proceed as follows:



1. The machine must be switched off.
2. Open the door.
3. Press and hold the forward button (fig. 5/1) and the reverse button (fig. 5/3) simultaneously.
4. Additionally press and let go of the function button (fig. 5/2).
  - All LED indicators on the display light up.
5. Let go of the forward button and the reverse button.
  - Now you are in the memory mode.
6. Press the forward button **twice** (fig. 5/1).
  - Now you are in the customization mode for automatic oiler output.
  - The LED indicator on the left side flashes showing the current settings.
7. Press the function button (fig. 5/2) so often until the needed oiler output mode comes on.
  - Each time you press the function button the output mode changes (Ample, Scarce, Normal)
8. Press the reverse button (fig. 5/3).
  - Now you are again in the memory mode.
9. Press the function button.
  - The selected settings are saved.
  - The machine switches off.
10. Close the door.

If you want to continue shredding turn the machine on: press the function button (fig. 5/2) briefly.

## 4 Malfunctions

### 4.1 Material jam in the machine (auto-reverse-funktion)

If a jam is caused by too much material being fed in the following happens:

- The cutters jam, then run in reverse for a short time (material is released) and stop.
- The motor switches off.
- The control display  (fig. 2/8) comes on. Proceed as follows:
  1. Remove any returned paper or briefly press the forward button (fig. 2/2).
    - The cutters now run forwards automatically and shred the remaining paper in the cutters. During the forward run the forward button (fig. 2/2) LED display  comes on. The control display  (fig. 2/8) goes out.
  2. Continue shredding with less paper.

### 4.2 Light barrier covered when door opened

Should there still be material in the feed slot when the door is opened, the motor switches off and the cutters stop. The control display  (fig. 2/8) comes on.

Close the door and acknowledge the status by pressing the forward button (fig. 2/2) briefly. The existing material is fed to the cutters and shredded.

### 4.3 Light barrier covered when machine turned on



Should there still be material in the feed slot when the machine is switched on the control display  (fig. 2/8) comes on.

1. Remove the material or
2. Press the forward button (fig. 2/2) briefly.
  - The existing material is fed to the cutters and shredded.

### 4.4 Motor protection

Should the motor be overloaded it switches off. The control display  (fig. 2/3) comes on. The machine can be started again after a cooling down period of about 15 – 20 minutes (depending on the model and the room temperature).

## 4.5 Electrical fault

If the function button (fig. 2/1) LED display  flashes or only the control display  (fig. 2/6) flashes there is an electrical fault.

1. Switch off the machine once.
2. Turn the machine on again.
  - This helps in many cases.

If the machine still fails to start up, please notify your dealer.

## 4.6 Fault check list

Should the machine not work, check the following points:

- is the plug connected to the power supply?
- is the door closed?
- is the receptacle full?
  - Follow the instructions under „Emptying the receptacle“, p. 14.
- Is there a material jam in the machine?
  - Follow the instructions in „Material jam in the machine“, p. 15.
- Is the motor overloaded?
  - See „Motor protection“, p. 15.

### NOTE!

In many cases, restarting the machine helps:

1. Switch off the machine once.
2. Turn the machine on again.

If none of these test points apply, please contact your dealer.

## 5 Maintenance / Disposing





### 5.1 Cutter maintenance (machines without automatic oil system)

Cross cut cutters must be oiled after 30 min operating time. If the control display  (fig. 2/7) comes on proceed as follows:

Spread some of the special oil provided on a sheet of paper and then feed this into the cutter via the feed slot.

The paper is drawn in and at the same time the cutter is supplied with oil for the necessary lubrication.

This procedure is acknowledged as follows to turn off the display after the cutters have been oiled:

1. Open the door until the control display  (fig. 2/6) lights up.
  - The control displays  and  flash.
2. Press the reverse button  (fig. 2/5) and keep it held down until the control display  goes out.
3. Close the door again.

The cutters now start a greasing cycle automatically (forward and reverse run) and then switch off. The machine is ready for use again. Should you need to re-order the special oil see „Accessories“, p. 18.

### 5.2 Cutter maintenance (machines with automatic oil system)

Cross-cut cutting mechanisms must be oiled regularly after a certain period of operation. This is done automatically by the integrated oiler.

If the control display  (fig. 2/7) flashes, this usually means that the oil container (fig. 6/3) is empty and must be replaced with a full container. The motor switches off.

### NOTE!

To complete the shredding process when the motor is switched off, press and hold the forward button (fig. 2/2).

- The cutting mechanism continues to run forward for approx. four seconds.

This process can only be activated once.

#### Changing the oil container:

1. Open the door.
  - The control display  (fig. 2/6) comes on.
  - The control display for the reverse button (fig. 2/5) and oil sensor (fig. 2/7) flashes.

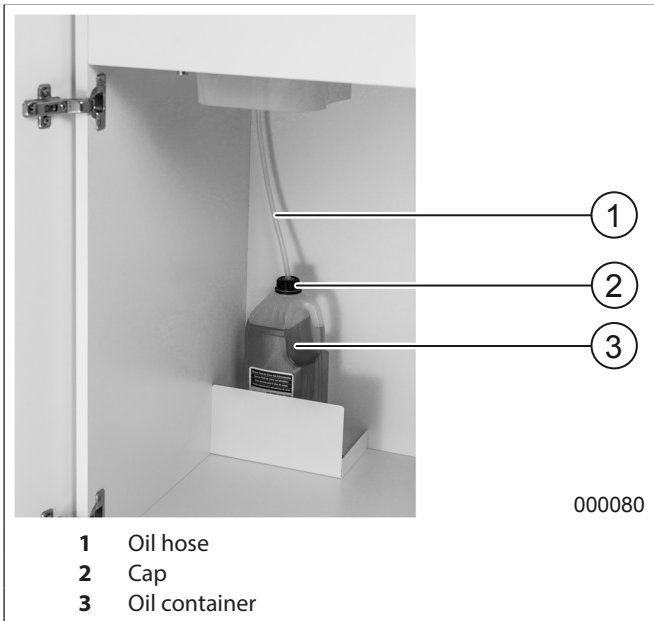



fig.6 Oil container

2. Release the screw cap (fig.6/2), take the oil hose with the screw cap out of the empty container and remove the container.
3. Suspend the full container and remove the screw cap. Feed the oil hose (fig.6/1) into the container and close the container again with the screw cap that is connected to the oil hose.
4. Press the reverse button (fig.2/5).
  - The control display  (fig.2/5) goes out.
5. Close the door.
  - The control display  (fig.2/6) goes out.
  - The control display (fig.2/7) goes out.

The machine is ready for use again. Should you need to re-order the special oil see „Accessories“, p. 18.

### 5.3 Cleaning the photocells



fig.7 Cleaning the photocells

If paper particles should come to rest in the inlet guide (for example after a paper jam) it is possible that the machine will not turn off, due to the broken light barrier.

To remove these paper strips and also to clean the photocell, pass another sheet of paper through the feed slot, or switch the machine off and wipe both “eyes” of the photocell with a brush (fig.7).

### 5.4 Automatic energy saving

If the machine is not used for a while it automatically switches off after about 15 minutes. The function button (fig.2/1) LED display  for “Ready” goes out. Press the function button briefly to turn it on again.

### 5.5 Disposing of the machine



Dispose of the machine in an environmentally friendly fashion at the end of its useful service life. Do not dispose of any of the parts included in the machine or its packaging with household waste.

## 6 Technical Data

Cutting size	
175SP2(SC2):	3,8 mm (stripes) 5,8 mm (stripes)
175CP4(CC3):	4x40 mm (cross-cut)
175CP5(CC4):	1,9x15 mm (cross-cut)
175CP6(CC5):	0,8x12 mm (cross-cut)
175CP7(CC6):	0,8x4,5 mm (cross-cut)
Cutting speed	
175SP2(SC2):	0,12 m/sec.
175CP4(CC3)/CP5(CC4):	0,13 m/sec.
175CP6(CC5):	0,15 m/sec.
175CP7(CC6):	0,23 m/sec.
Cutting capacity	
175SP2(SC2) 3,8 mm	40-45 sheets (70g/m <sup>2</sup> )
175SP2(SC2) 5,8 mm	65-70 sheets (70g/m <sup>2</sup> )
175CP4(CC3):	40-50 sheets (70g/m <sup>2</sup> )
175CP5(CC4):	25-30 sheets (70g/m <sup>2</sup> )
175CP6(CC5):	15-17 sheets (70g/m <sup>2</sup> )
175CP7(CC6):	8-10 sheets (70g/m <sup>2</sup> )
Supply voltage:	230 V/50 Hz, 240 V/50 Hz, 120 V/60 Hz, 100V/50/60Hz
Pre-fusing (slow-blow):	230 V/50 Hz = 16 amps 240 V/50 Hz = 13 amps 120 V/60 Hz = 20 amps
Working width:	405 mm
Noise level:	approx. 52 dB (A)
Power:	1,1 kW
Dimensions (WxDxH):	660 x 560 x 1050 mm
Weight:	approx. 90 kg

## 7 Accessories

Description	Order-No.
Plastic bag, 600 x 500 x 1000 x 0,05 mm	99952
Lubricant, 110 ml bottle	88035
Oil container, 2000 ml	91869



### NOTE!

For orders of accessories and spare parts please contact your dealer.



# Table des matières

<b>1</b>	<b>Recommandations de sécurité ...</b>	<b>19</b>	4.3	Barriere lumineuse occupee lors de la mise en marche .....	24
<b>2</b>	<b>Mise en marche .....</b>	<b>20</b>	4.4	Protection du moteur .....	24
2.1	Domaines d'utilisation .....	20	4.5	Dysfonctionnement electrique .....	24
2.2	Installation .....	20	4.6	Liste de controle en cas de pannes .....	24
<b>3</b>	<b>Utilisation .....</b>	<b>20</b>	<b>5</b>	<b>Entretien / Elimination .....</b>	<b>24</b>
3.1	Elements de commande .....	20	5.1	Entretien du bloc de coupe sans lubrificateur automatique .....	24
3.2	Mise en marche de la machine .....	22	5.2	Entretien du bloc de coupe avec lubrificateur automatique .....	24
3.3	Alimentation de materiau .....	22	5.3	Nettoyage des cellules photoelectriques ..	25
3.4	Vider la corbeille .....	22	5.4	Mode automatique economie d'energie ..	25
3.5	Affichage dynamique de sollicitation .....	23	5.5	Elimination de la machine .....	25
3.6	Modifier le volume d'huile .....	23	<b>6</b>	<b>Caractéristiques techniques .....</b>	<b>26</b>
<b>4</b>	<b>Comment remedier aux petites pannes .....</b>	<b>23</b>	<b>7</b>	<b>Accessoires .....</b>	<b>26</b>
4.1	Bourrage de materiau dans l'appareil .....	23	<b>8</b>	<b>Certificate of Conformity .....</b>	<b>35</b>
4.2	Barriere lumineuse occupee lors de l'ouverture de porte .....	24			

## 1 Recommandations de sécurité



### Danger !

#### Risque de blessure ! Endommagement de la machine !

- ☞ Les grilles permettent une aération de l'appareil, par conséquent ne pas couvrir !
- ☞ Le raccordement au secteur de la machine doit être librement accessible et doit se trouver à proximité de la machine !
- ☞ Utiliser la machine uniquement dans des locaux fermés et tempérés (10 – 25 °C) !
- ☞ Toujours fermer lentement la porte du boîtier ouverte afin de ne pas mettre en péril le circuit électronique..



#### La machine ne doit pas être utilisée par plusieurs personnes en même temps !

La conception des éléments de sécurité repose sur une mise en service sans danger pour "L'utilisation de la machine par une seule personne".



#### Ne pas effectuer d'autres activités sur la machine (par ex. nettoyage...) durant le procédé de destruction !



#### La machine n'est pas un jouet et ne convient pas pour être utilisée par des enfants !

Le concept global de sécurité (dimensions, orifices d'alimentation, mises hors circuit de sécurité, etc.) de cette machine ne fournit aucune garantie pour une manipulation sans danger par les enfants.



#### Risque de blessure! N'approchez jamais du bloc de coupe les vêtements amples, colliers, cheveux longs, cravates etc !



#### Risque de blessure! N'introduisez jamais les doigts dans l'ouverture !



#### En cas de danger, arrêter la machine par l'interrupteur principal, ou par l'interrupteur d'urgence, ou débranchez la machine !



#### Débrancher le raccordement réseau avant d'ouvrir l'installation !

Les travaux de réparation doivent être effectués uniquement par un spécialiste !

## 2 Mise en marche

### 2.1 Domaines d'utilisation



#### Attention !

**Endommagement du bloc de coupe !**  
**La machine peut servir uniquement à broyer du papier !**

Le broyage de supports de données d'autres types, comme pour les modèles avec une largeur de coupe 0,8x12 mm (CP6/CC5) ou 0,8x4,5 mm (CP7/CC6), ou bien encore d'agrafes et de trombones risque de causer des blessures sur la personne (par exemple par l'éclatement de matériaux solides etc.) et d'entraîner des dégâts sur la machine (par exemple la destruction du bloc de coupe).

**Exception:** Les modèles avec une largeur de coupe en **3,8mm, 5,8mm, 4x40mm, 1,9x15mm** peuvent également détruire des CD ou des disquettes informatiques de 3,5" un par un.

Le destructeur de documents **intimus 175SP2(SC2)/CP4(CC3)/CP5(CC4)/CP6(CC5)/CP7(CC6)** est un appareil destiné à détruire des documents courants.

### 2.2 Installation

1. Déballez et installez la machine.
2. Mettre le sac en plastique dans la corbeille.
3. **Seulement machines avec lubrificateur automatique:** Pour le montage du tuyau d'huile (fig. 1/1) enlever la vis (fig. 1/2).

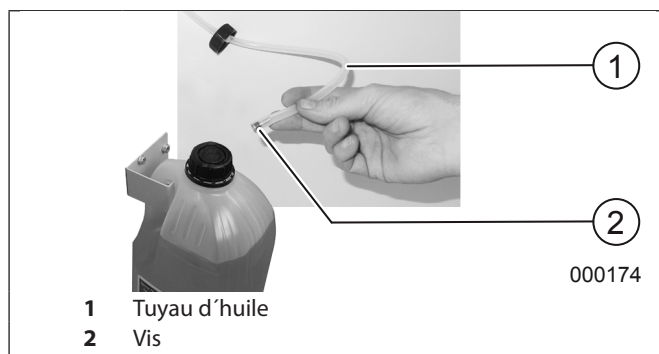
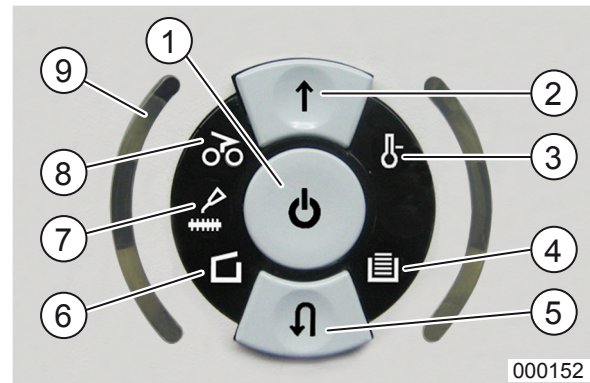

fig.1 Le montage du tuyau d'huile

4. Raccorder l'appareil au réseau électrique à l'aide de la fiche secteur (voir les indications concernant le fusible auxiliaire requis pour la prise secteur dans les « Caractéristiques techniques », p. 26.

## 3 Utilisation

### 3.1 Elements de commande



- 1 Touche de fonction
- 2 Touche de marche avant
- 3 Voyant de contrôle « Surcharge du moteur » / « Dysfonctionnement électrique »
- 4 Voyant de contrôle « Corbeille pleine »
- 5 Touche de marche arrière « Stop »/« En arrière »
- 6 Voyant de contrôle « Porte ouverte » / « Perturbation porte »
- 7 Voyant de contrôle « Lubrifier bloc de coupe » / « Changement du réservoir d'huile »
- 8 Voyant de contrôle « Bourrage de matériau »
- 9 Voyant de contrôle « Facteur d'utilisation du moteur »

fig.2 Elements de commande „i-control“

#### ① = Touche de fonction (fig. 2/1)

##### a) « Prêt à fonctionner »

Frapper brièvement sur cette touche pour commuter la machine sur « prêt à fonctionner ». Simultanément, le voyant LED intégré  $\odot$  s'allume.

##### b) « Arrêt »

Maintenir enfoncée cette touche dans l'état « prêt à fonctionner » pendant env. 3 secondes pour éteindre la machine.

#### ! REMARQUE !

La machine s'éteint automatiquement en cas de non utilisation pendant un laps de temps d'environ 15 minutes.

##### c) « Stop »

Frapper brièvement sur cette touche pendant que le bloc de coupe fonctionne pour éteindre et arrêter celui-ci.

#### ② = Touche de marche avant (fig. 2/2)

Une frappe sur cette touche a pour effet de faire avancer le bloc de coupe pendant quelques secondes, par ex. pour faire sortir un document resté dans le bloc de coupe. Simultanément, le voyant LED intégré  $\uparrow$  s'allume.

En appuyant sur cette touche et en la maintenant enfoncée lorsque le moteur est à l'arrêt, le bloc de coupe se déplace en marche arrière.

**③ = Voyant de contrôle (fig. 2/3) « Surcharge du moteur » / « Dysfonctionnement électrique »**

Lire la description des manières de procéder sous la rubrique « *Comment remédier aux petites pannes* », p. 23.

**a) « Protection du moteur »**

S'allume lorsque le moteur a subi une surcharge et qu'il s'est éteint. La machine ne peut être démarrée pendant la phase de refroidissement du moteur.

**b) « Dysfonctionnement électrique »**

Clignote en présence d'un dysfonctionnement électrique sur le circuit imprimé de commande. La machine s'éteint. Veuillez en informer votre distributeur spécialisé.

**④ = Voyant de contrôle (fig. 2/4) « Corbeille pleine »**

Luit quand la corbeille est pleine et qu'il faut le vider. Le mécanisme de coupe est coupé.

**⑤ = Touche de marche arrière (fig. 2/5)**
**a) « Stop »**

Frapper brièvement sur cette touche pendant que le bloc de coupe fonctionne pour éteindre et arrêter celui-ci.

**b) « En arrière »**

En appuyant sur cette touche et en la maintenant enfoncée lorsque le moteur est à l'arrêt, le bloc de coupe se déplace en marche arrière. Dans le même temps, le voyant LED intégré  s'allume.

**⑥ = Voyant de contrôle (fig. 2/6)**
**a) « Porte ouverte »**

S'allume lorsque la porte de l'armoire inférieure est ouverte. Le moteur s'éteint automatiquement et ne peut être démarrée tant que la porte reste ouverte.

**b) « Perturbation porte »**

Clignote, lorsque le capteur de porte présente un dysfonctionnement électrique. Le moteur s'éteint. Veuillez en informer votre distributeur spécialisé.

**⑦ = Kontroll-Anzeige (fig. 2/7)**
**a) « Lubrifier bloc de coupe » (machines sans lubrificateur automatique)**

S'allume lorsque le bloc de coupe de la version Cross-Cut doit être lubrifié. L'opération de lubrification doit être validée sur la touche de marche arrière (fig. 2/5) (voir description « *Entretien du bloc de coupe sans lubrificateur automatique* », p. 24).

**b) « Changement du réservoir d'huile » (machines avec lubrificateur automatique)**

Le voyant de contrôle clignote quand le réservoir d'huile est vide et doit être remplacé par un réservoir plein. Le moteur est éteint. Le remplacement du réservoir d'huile doit être acquitté avec la touche marche arrière (fig. 2/5) (voir « *Entretien du bloc de coupe avec lubrificateur automatique* », p. 24).

**! REMARQUE !**

Lorsque ce voyant clignote, le moteur est éteint. Le moteur ne peut démarrer que si le réservoir d'huile vide a été remplacé par un réservoir plein.

**⑧ = Voyant de contrôle (fig. 2/8)**

Lire la description des manières de procéder sous la rubrique « *Comment remédier aux petites pannes* », p. 23.

**a) « Bourrage de matériau dans l'appareil »**

S'allume lorsque la quantité de matériau chargée dans le bloc de coupe est trop importante. Le bloc de coupe se bloque, se déplace ensuite un peu vers l'arrière et s'arrête. Le moteur s'éteint.

**b) « Barrière lumineuse occupée lors de l'ouverture de porte »**

S'allume lorsque du matériau se trouve encore dans l'une des fentes d'alimentation lors de l'ouverture de la porte. Le bloc de coupe s'arrête. Le moteur s'éteint.

**c) « Barrière lumineuse occupée lors de la mise en marche »**

S'allume lorsque du matériau se trouve dans l'une des fentes d'alimentation lors de la mise en marche de la machine.

**⑨ = Voyant de contrôle (fig. 2/9) « Facteur d'utilisation du moteur »**

Lors du procédé de broyage, il affiche au moyen d'une DEL couleur, le facteur d'utilisation actuelle du moteur (voir description sous « *Affichage dynamique de sollicitation* », p. 23).

## Barrière lumineuse

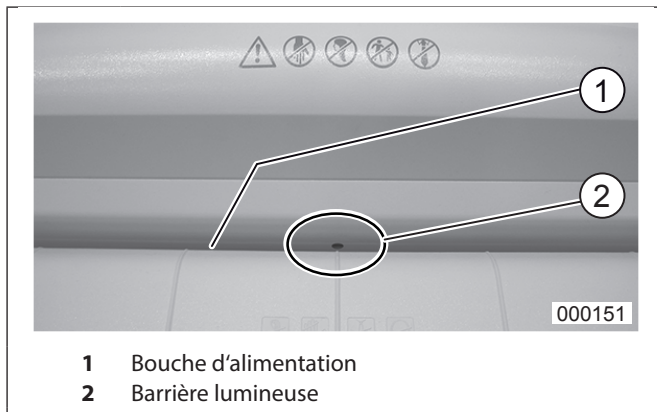

- 1 Bouche d'alimentation  
2 Barrière lumineuse

fig. 3 Barrière lumineuse

Démarre le procédé de broyage dès que du matériau est introduit dans la bouche d'alimentation (fig. 3/1). Simultanément, le voyant LED intégré ↑ de la touche marche avant s'allume.

## 3.2 Mise en marche de la machine

Actionner brièvement la touche de fonction (fig. 2/1).

- Le voyant LED ☉ de la touche de fonction s'allume et affiche « prêt à fonctionner ».
- La machine peut être alimentée.

## 3.3 Alimentation de matériau



### Attention !

#### Endommagement de la machine !

- △ Ne jamais alimenter l'appareil avec une quantité de matériau supérieure au maximum indiqué (voir « Caractéristiques techniques », p. 26)!
- △ Si malgré tout, une quantité trop importante de matériau parvient dans le bloc de coupe, voir « Bourrage de matériau dans l'appareil », p. 23.

Amener le papier au bloc de coupe par la fente d'entrée (fig. 3/1).

- La machine se met automatiquement en marche avant et détruit le papier.
- Après cette opération de destruction, le moteur s'arrête auto-matiquement.



#### REMARQUE !

Pour le broyage de films transparents, il convient de commuter la machine manuellement sur la marche avant (maintenir la touche marche avant (fig. 2/2) enfoncée).

La machine s'éteint automatiquement en cas de non utilisation pendant un laps de temps d'environ 15 minutes.

## 3.4 Vider la corbeille

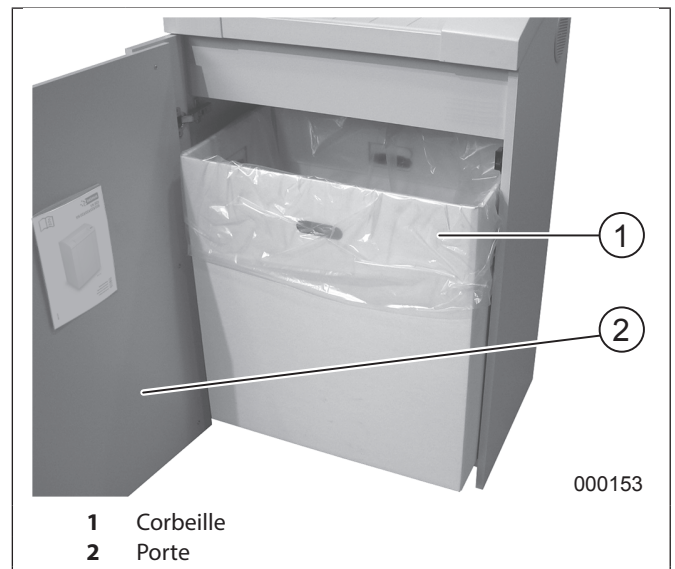

- 1 Corbeille  
2 Porte

fig. 4 Corbeille

Quand la corbeille est pleine, le moteur s'éteint. Le voyant de contrôle ☒ (fig. 2/4) s'allume.



#### REMARQUE !

- Pour terminer le processus de destruction avec le moteur éteint, maintenir la touche marche avant (fig. 2/2) enfoncée.
- Le bloc de coupe se déplace en marche avant pendant encore quatre secondes environ.
- Cette opération ne peut être déclenchée qu'une seule fois.

Vider la corbeille (fig. 4/1) comme suit :

1. Ouvrir la porte (fig. 4/2).
  - Le voyant de contrôle ☒ (fig. 2/6) luit.
  - Quand il y a encore du matériau dans la bouche d'alimentation, le voyant de contrôle ☒ (fig. 2/8) luit aussi.
2. Retirer le sac plein et vider le contenu.
  - Le voyant de contrôle ☒ (fig. 2/4) s'éteint.
3. Insérer le sac vide.
4. Fermer la porte.
  - Le voyant de contrôle ☒ (fig. 2/6) s'éteint.
5. Si le voyant de contrôle ☒ s'allume, actionner brièvement la touche de marche avant (fig. 2/2). Le matériau resté dans la fente d'alimentation est broyé et le voyant s'éteint.
  - La machine est prête à fonctionner.



#### REMARQUE !

La machine fonctionne uniquement lorsque la porte est fermée !



### 3.5 Affichage dynamique de sollicitation

Pendant le processus de broyage, un voyant de contrôle à LED (fig. 2/9) indique le degré de sollicitation du moteur :

- Lumière verte : Sollicitation < 75 %
- Lumière rouge : Sollicitation 75 - 100 %

Le voyant de contrôle doit rester allumé en vert afin d'éviter un bourrage de matériau !

#### **!** REMARQUE !

Le système d'affichage de la charge se calibre automatiquement ! Il peut en découler un affichage modifié de la charge (p. ex. l'affichage s'allume en rouge en marche à vide). Il ne s'agit pas d'un défaut de qualité. L'affichage de charge se normalise après plusieurs destructions.

### 3.6 Modifier le volume d'huile

(Machines avec lubrificateur automatique)

Le volume d'huile du lubrificateur automatique peut être adapté à vos besoins.

#### a) Ample Mode

Les pompes à huile acheminent env. 25 % d'huile **en plus** qu'en mode normal vers le bloc de coupe.

#### b) Normal Mode

est le réglage standard.

#### c) Scarce Mode

Les pompes à huile acheminent env. 25 % d'huile **en moins** qu'en mode normal vers le bloc de coupe.

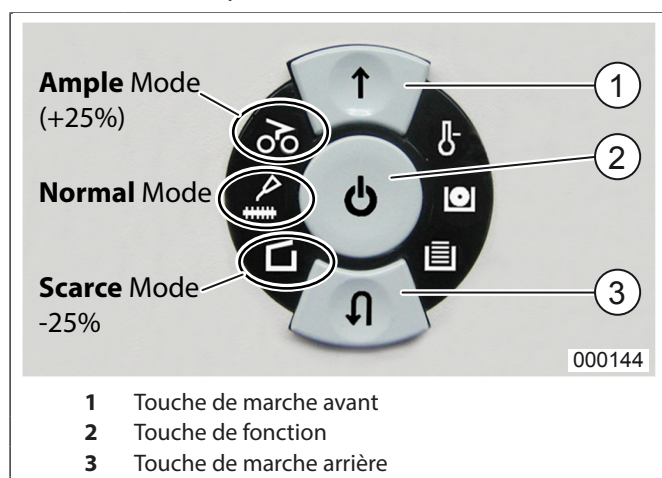

fig. 5 Modifier le volume d'huile

Pour modifier le volume d'huile, procédez comme suit :

1. La machine doit être éteinte !
2. Ouvrir la porte.
3. Appuyer simultanément sur la touche marche

avant (fig. 5/1) et la touche marche arrière (fig. 5/3) et les maintenir enfoncées.

4. En outre, appuyez sur la touche de fonction (fig. 5/2) et relâchez-la.
  - Toutes les LED s'allument.
5. Relâcher les touches marche avant et marche arrière.
  - Vous êtes en mode enregistrement.
6. Actionner **deux fois** la touche de marche avant.
  - Vous êtes en mode de réglage du volume d'huile.
  - La LED située sur le côté gauche clignote et montre le réglage actuel.
7. Appuyez plusieurs fois sur la touche fonction (fig. 5/2) jusqu'à ce que le niveau souhaité de volume d'huile s'allume (fig. 5).
  - Le niveau du volume d'huile (Ample, Scarce, Normal) change à chaque pression de la touche.
8. Appuyer la touche marche arrière.
  - Vous êtes à nouveau en mode enregistrement.
9. Appuyer sur la touche de fonction.
  - Le réglage choisi est enregistré.
  - La machine est éteinte.
10. Fermer la porte.

Si vous voulez continuer avec le déchiquetage, rallumez la machine : Actionner brièvement la touche de fonction (fig. 5/2).

## 4 Comment remédier aux petites pannes

### 4.1 Bourrage de matériau dans l'appareil (Fonction Auto-Reverse)

Si une quantité trop importante de matériau provoque un bourrage, la machine réagit comme suit :

- Le bloc de coupe se bloque, se déplace ensuite un peu vers l'arrière (ce qui libère le matériau) et s'arrête.
- Le moteur s'éteint.
- Le voyant de contrôle (fig. 2/8) s'allume.

Procéder comme suit :

1. Retirer le papier expulsé et actionner brièvement la touche marche avant (fig. 2/2).
  - Le coupe de bloc avance maintenant automatiquement et broie les résidus de papier restés dans le bloc de coupe. En cours de marche avant, le voyant LED de la touche marche avant s'allume. Le voyant de contrôle s'éteint.
2. Poursuivre le broyage avec une quantité de papier plus faible.



## 4.2 Barrière lumineuse occupée lors de l'ouverture de porte

S'il y a encore du matériau dans la bouche d'alimentation en ouvrant la porte, le moteur se coupe et le mécanisme de coupe s'arrête. Le voyant de contrôle  (fig. 2/8) luit.

Fermer la porte et valider l'état en actionnant brièvement la touche de marche avant (fig. 2/2). Le matériau présent passe dans le bloc de coupe et est broyé.

## 4.3 Barrière lumineuse occupée lors de la mise en marche



S'il y a encore du matériau dans la bouche d'alimentation en enclenchant la machine, le voyant de contrôle  (fig. 2/8) luit.

1. Retirer le matériau ou
2. Actionner brièvement la touche de marche avant (fig. 2/2).
  - Le matériau présent passe dans le bloc de coupe et est broyé.

## 4.4 Protection du moteur

Le moteur s'éteint s'il est surchargé. Le voyant de contrôle  (fig. 2/3) s'allume. Après une période de refroidissement d'environ 15 à 20 minutes (suivant le modèle et la température ambiante), il est possible de redémarrer l'appareil.

## 4.5 Dysfonctionnement électrique

Il y a dysfonctionnement électrique si le voyant LED  de la touche de fonction (fig. 2/1) ou si seul le voyant de contrôle  (fig. 2/6) clignote.

1. Mettre la machine à l'arrêt.
2. Remettre la machine en marche.
  - Cela suffit à résoudre le problème dans la plupart des cas.

Si la machine ne démarre toujours pas, veuillez prévenir votre revendeur.

## 4.6 Liste de contrôle en cas de pannes

Si l'appareil ne fonctionne pas, vérifier les points ci-après :

- La fiche secteur est-elle raccordée au secteur ?
- La porte est-elle fermée ?
- Est-ce que la corbeille est pleine ?
  - Suivez les instructions qui figurent sous « *Vider la corbeille* », p. 22.
- Y a-t-il un bouchage de matériau dans l'appareil ?
  - Suivre les instructions « *Bouchage de matériau dans l'appareil* », p. 23.

- Le moteur a-t-il été surchargé ?
  - Voir sous « *Protection du moteur* », p. 24.

### ! REMARQUE !

Dans la plupart des cas, un redémarrage de la machine permet de résoudre le problème :

1. Mettre la machine à l'arrêt.
2. Remettre la machine en marche.

Si aucun des points de contrôle n'est pertinent, veuillez en informer votre distributeur spécialisé.

## 5 Entretien / Elimination





### 5.1 Entretien du bloc de coupe sans lubrificateur automatique

Les blocs de coupe Cross-Cut doivent être lubrifiés après avoir fonctionné 30 min. Si le voyant de contrôle  (fig. 2/7) s'allume, procéder comme suit:

Répartir un peu d'huile spéciale jointe à la livraison sur une feuille de papier et introduire cette dernière dans la bouche d'alimentation du bloc de coupe.

Le papier est introduit et graisse ainsi le bloc de coupe.

Remarque: Afin de faire disparaître les voyants de contrôle, il convient de valider la fin de l'opération de lubrification du bloc de coupe comme suit:

1. Ouvrir la porte jusqu'à ce que le voyant de contrôle  (fig. 2/6) s'allume.
  - Les voyants de contrôle  et  clignotent.
2. Actionner la touche de marche arrière (fig. 2/5) et la maintenir enfoncée jusqu'à ce que le voyant de contrôle  (7) s'éteigne.
3. Refermer la porte.

Le bloc de coupe commence maintenant automatiquement un cycle de lubrification (course marche avant/course marche arrière) et ensuite il s'éteint. La machine est à nouveau prête à fonctionner. Pour recommander ultérieurement de l'huile spéciale, voir « *Accessoires* », p. 26.

### 5.2 Entretien du bloc de coupe avec lubrificateur automatique

Les blocs de coupe Cross-Cut doivent régulièrement être lubrifiés, après un certain temps de fonctionnement. Cela est effectué automatiquement par le lubrificateur monté.

Si le voyant de contrôle clignote  (fig. 2/7), cela signifie normalement que le réservoir d'huile (fig. 6/3) est vide et qu'il doit être remplacé par un réservoir plein. Le moteur s'éteint.

**! REMARQUE !**

Pour terminer le processus de destruction avec le moteur éteint, maintenir la touche marche avant (fig. 2/2) enfoncée.

- Le bloc de coupe se déplace en marche avant pendant encore quatre secondes environ.

Cette opération ne peut être déclenchée qu'une seule fois.

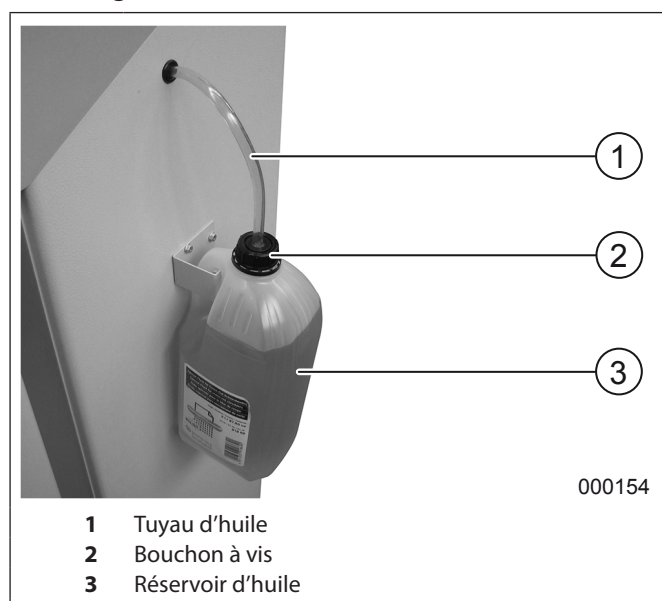

**Changer le réservoir d'huile :**

1. Ouvrir la porte (fig. 4/2)
  - Le voyant de contrôle  (fig. 2/6) luit.
  - Le voyant de contrôle de la touche marche arrière (fig. 2/5) et lubrifier bloc de coupe (fig. 2/7) clignote.



- 1 Tuyau d'huile
- 2 Bouchon à vis
- 3 Réservoir d'huile

fig.6 Réservoir d'huile

2. Enlever le capuchon (fig.6/2), retirer le tuyau d'huile avec le capuchon du réservoir vide et ôter le réservoir.
3. Accrocher le réservoir plein et ôter le capuchon. Introduire le tuyau d'huile (fig.6/1) dans le réservoir d'huile et refermer le réservoir avec le capuchon se trouvant au niveau du tuyau d'huile.
4. Appuyer sur la touche marche arrière (fig. 2/5).
  - Le voyant de contrôle  (fig. 2/5) s'éteint.
5. Fermer la porte.
  - Le voyant de contrôle  (fig. 2/6) s'éteint.
  - Le voyant de contrôle  (fig. 2/7) s'éteint.

La machine est à nouveau prête à fonctionner. Pour recommander ultérieurement de l'huile spéciale, voir « Accessoires », p. 26.

### 5.3 Nettoyage des cellules photoélectriques



fig.7 Nettoyage des cellules photoélectriques

Il est possible que des morceaux de papier restent dans la rainure d'admission (par ex. après un bourrage de papier) et empêchent la barrière lumineuse « occupée » d'arrêter l'appareil.

Il est possible d'enlever ces morceaux de papier ou de nettoyer les cellules photoélectriques, soit en introduisant une nouvelle feuille de papier dans le bloc de coupe, soit en déclenchant la marche arrière et en passant brièvement un pinceau sur les « yeux » des cellules photoélectriques (fig.7).

### 5.4 Mode automatique économie d'énergie

Lorsque la machine n'est pas utilisée pendant un certain temps, elle s'éteint automatiquement après environ 15 minutes. Le voyant LED  de la touche de fonction (fig. 2/1) indiquant « prêt à fonctionner » s'éteint. Actionner brièvement la touche de fonction pour remettre la machine en marche.

### 5.5 Elimination de la machine



Lorsqu'elle est en fin de durée de vie, toujours éliminer la machine de façon conforme à l'environnement. Ne jamais jeter aucune pièce de la machine ou de l'emballage avec les ordures ménagères.

## 6 Caractéristiques techniques

Largeur de coupe	
175SP2(SC2):	3,8 mm (en bandes) 5,8 mm (en bandes)
175CP4(CC3):	4x40 mm (Cross-Cut)
175CP5(CC4):	1,9x15 mm (Cross-Cut)
175CP6(CC5):	0,8x12 mm (Cross-Cut)
175CP7(CC6):	0,8x4,5 mm (Cross-Cut)
Vitesse de coupe	
175SP2(SC2):	0,12 m/sec.
175CP4(CC3)/CP5(CC4):	0,13 m/sec.
175CP6(CC5):	0,15 m/sec.
175CP7(CC6):	0,23 m/sec.
Capacité de coupe	
175SP2(SC2) 3,8 mm	40-45 feuilles (70g/m <sup>2</sup> )
175SP2(SC2) 5,8 mm	65-70 feuilles (70g/m <sup>2</sup> )
175CP4(CC3):	40-50 feuilles (70g/m <sup>2</sup> )
175CP5(CC4):	25-30 feuilles (70g/m <sup>2</sup> )
175CP6(CC5):	15-17 feuilles (70g/m <sup>2</sup> )
175CP7(CC6):	8-10 feuilles (70g/m <sup>2</sup> )
Tension de ligne:	
	230 V/50 Hz, 240 V/50 Hz, 120 V/60 Hz, 100V/50/60Hz
Fusible (à action retardée):	
	230 V/50 Hz = 16 A 240 V/50 Hz = 13 A 120 V/60 Hz = 20 A
Largeur de travail:	
	405 mm
Niveau de bruit:	
	ca. 52 dB (A)
Puissance:	
	1,1 kW
Dimensions: (LxPxH):	
	660 x 560 x 1050 mm
Poids:	
	ca. 90 kg

## 7 Accessoires

Désignation	Ordre-No.
Sac en plastique, 600 x 500 x 1000 x 0,05 mm	99952
Flacon d'huile special, 110 ml	88035
Flacon d'huile special, 2000 ml	91869



### REMARQUE !

Pour les accessoires et pièces détachées, veuillez contacter votre agent.

# Índice

<b>1</b>	<b>Indicaciones de seguridad</b> .....	<b>27</b>	4.4	Guardamotor .....	32
<b>2</b>	<b>Puesta en servicio</b> .....	<b>28</b>	4.5	Avería eléctrica .....	32
2.1	Campo de aplicación .....	28	4.6	Lista de verificación en las averías .....	32
2.2	Colocacion .....	28	<b>5</b>	<b>Mantenimiento / Eliminación</b> ....	<b>32</b>
<b>3</b>	<b>Manejo</b> .....	<b>28</b>	5.1	Mantenimiento del mecanismo de corte sin lubricador automático .....	32
3.1	Elementos de mando .....	28	5.2	Mantenimiento del mecanismo de corte con lubricador automático .....	32
3.2	Cómo conectar el aparato .....	30	5.3	Limpieza de las fotocélulas .....	33
3.3	Alimentación de material .....	30	5.4	Función automática de ahorro energético .	33
3.4	Cómo vaciar el recipiente de recogida .....	30	5.5	Eliminación del aparato usado .....	33
3.5	Indicador dinámico de carga .....	31	<b>6</b>	<b>Datos técnicos</b> .....	<b>34</b>
3.6	Modificación del caudal de aceite .....	31	<b>7</b>	<b>Accesorio</b> .....	<b>34</b>
<b>4</b>	<b>Avería</b> .....	<b>31</b>	<b>8</b>	<b>Certificate of Conformity</b> .....	<b>35</b>
4.1	Material atascado en el aparato .....	31			
4.2	Barrera fotoeléctrica tapada por apertura de puerta .....	32			
4.3	Barrera fotoeléctrica tapada por conexión .	32			

## 1 Indicaciones de seguridad



### ¡Peligro!

#### ¡Peligro de lesión! ¡Daños a la máquina!

- ☞ ¡Las aberturas de rejilla en la caja están previstas como refrigeración y no deben ser tapadas sin cubiertas con cualquier tipo de objeto!
- ☞ ¡La toma de conexión a la red de la máquina tiene que encontrarse en un lugar fácilmente accesible y en las inmediaciones de la máquina!
- ☞ ¡La máquina sólo se deberá usar en recintos cerrados y con temperaturas comprendidas entre 10 – 25°C!
- ☞ Cierre siempre lentamente la puerta de la carcasa para no dañar el mecanismo electrónico.



#### ¡El aparato no debe ser operado por varias personas al mismo tiempo!

La concepción de los elementos de seguridad se basa en un manejo sin peligro en un „servicio por una sola persona“.



#### ¡Durante el proceso de trituración no se deben efectuar otros trabajos en la máquina (p. ej. limpieza etc.)!



#### ¡La máquina no es un juguete y no es apropiada para el empleo y uso por parte de niños!

El concepto global en razón de la seguridad (dimensiones, orificios de alimentación, desconexiones de seguridad, etc.) de esta máquina no incluye ningún tipo de garantía en cuanto a un manejo inofensivo por parte de niños.



#### ¡Peligro de lesión! No acercarse a la apertura de alimentación piezas sueltas de ropa, corbatas, bisutería, cabello largo u otros objetos sueltos!



#### ¡Peligro de lesión! No introducir los dedos en la apertura de alimentación!



#### ¡En caso de emergencia desconectar el aparato usando el interruptor principal o el interruptor de emergencia, o extraer la clavija de red!



#### Antes de abrir el aparato hay que extraer la clavija de red!

¡Las reparaciones solamente debe efectuarlas un técnico especialista!

## 2 Puesta en servicio

### 2.1 Campo de aplicación



#### ¡Atención!

¡Daños al mecanismo de corte!

¡La máquina solamente debe ser utilizada para el desmenuzamiento de papel!

La trituración de soportes de datos de otro tipo así como en los modelos con una anchura de corte de 0,8x12 mm (CP6/CC5) o bien 0,8x4,5 mm (CP7/CC6) también la trituración de grapas y clips puede conllevar lesiones en personas (p. ej. debido a la fragmentación de materiales sólidos, etc.) así como daños en el aparato (p. ej. la destrucción del mecanismo de corte, etc.).

**Excepción:** En los modelos con una anchura de corte de **3,8mm, 5,8mm, 4x40mm, 1,9x15mm** es posible desmenuzar también CD's o discos de ordenador de 3,5" individuales.

El shredder de datos **intimus 175SP2(SC2)/CP4(CC3)/CP5(CC4)/CP6(CC5)/CP7(CC6)** es un aparato para la trituración de información escrita.

### 2.2 Colocación

1. Desembalaje y colocación del aparato.
2. Introducir saco de plástico en el recipiente de recogida.
3. Sólo máquinas con lubricador automático: Para la instalación del sistema de lubricación retirar el tornillo (Fig. 1/2) del conducto del aceite (Fig. 1/1).



- 1 Conducto del aceite
- 2 Tornillo

Fig. 1 Instalación del sistema de lubricación

4. Enchufe el aparato a la red (ver las indicaciones sobre el fusible previo necesario del tomacorriente en „Datos técnicos“, p. 34.

## 3 Manejo

### 3.1 Elementos de mando

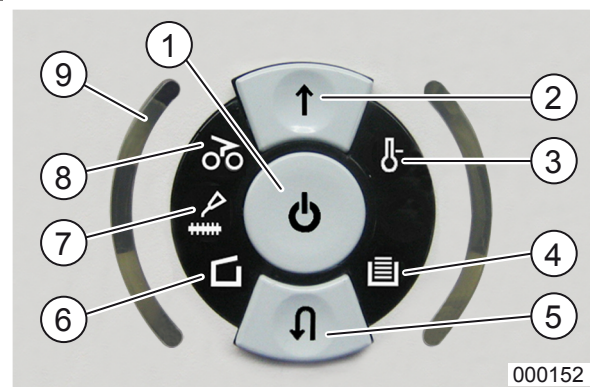

- 1 Pulsador funcional
- 2 Pulsador de avance
- 3 Indicador de control "Sobrecarga de motor" / "Avería eléctrica"
- 4 Indicador de control „Recipiente de recogida lleno“
- 5 Pulsador de retroceso "Parada" / "Hacia atrás"
- 6 Indicador de control "Puerta abierta" / "Avería eléctrica"
- 7 Indicador de control „Engrasar mecanismo de corte“ / „Cambio del recipiente de aceite“
- 8 Indicador de control „Material atascado“
- 9 Indicador de control "Grado de carga del motor"

Fig. 2 Elementos de mando „i-control“

#### ① = Pulsador funcional (Fig. 2/1)

##### a) "Listo para el uso"

Accionando brevemente este pulsador se conecta el equipo en el modo de funcionamiento "listo para el uso".

Al mismo tiempo se encenderá el indicador piloto integrado .

##### b) "Apagado"

Si se acciona este pulsador en el modo de funcionamiento "Listo para el uso" aprox. por 3 seg., la máquina se desconectará.

#### ! ¡NOTA!

Si la máquina no se utiliza durante un periodo de tiempo de aprox. 15 min., se apagará automáticamente.

##### c) "Parada"

Al accionar brevemente este pulsador mientras el mecanismo de corte está en marcha, se desconectará éste y se quedará parado.

#### ② = Pulsador de avance (Fig. 2/2)

Accionando este pulsador, el mecanismo de corte avanzará unos pocos segundos, por ejemplo, para sacar el material que aún se encuentra en el mecanismo de corte. Al mismo tiempo se encenderá el indicador piloto integrado .

Pulsando y manteniendo este botón cuando el motor está parado, el mecanismo de corte gira en avance.



**③ = Indicador de control (Fig. 2/3) "Sobrecarga de motor" / "Avería eléctrica"**

Para el modo de proceder consulte la descripción correspondiente en el apartado „Avería“, p. 31.

**a) "Guardamotor"**

Se enciende cuando el motor se ha sobrecargado y desconectado. La máquina no se puede activar durante la fase de enfriamiento del motor.

**b) "Avería eléctrica"**

**parpadea**, si ha surgido una avería eléctrica dentro de la placa de circuitos impresos del sistema de mando. La máquina se desconecta. Avise al comercio especializado más cercano.

**④ = Indicador de control (Fig. 2/4) "Recipiente de recogida lleno"**

Se enciende cuando el recipiente de recogida está lleno y se ha de vaciar.

El mecanismo de corte se desconecta.

**⑤ = Pulsador de retroceso (Fig. 2/5)**
**a) "Parada" / "Hacia atrás"**

Al accionar brevemente este pulsador mientras el mecanismo de corte está en marcha, se desconectará éste y se quedará parado.

**b) "Hacia atrás"**

Al mantener accionado este pulsador con el motor parado, el mecanismo de corte funcionará en modo de retroceso. Al mismo tiempo, se encenderá el indicador piloto integrado

**⑥ = Indicador de control (Fig. 2/6)**
**a) "Puerta abierta"**

Se enciende si la puerta del armario inferior está abierta. El motor se desconecta automáticamente y no se puede conectar mientras la puerta siga estando abierta.

**b) "Avería eléctrica"**

**parpadea**, si ha surgido una avería eléctrica en los sensores de la puerta. El motor se desconecta. Avise al comercio especializado más cercano.

**⑦ = Kontroll-Anzeige (Fig. 2/7)**
**a) „Engrasar mecanismo de corte“ (Máquinas sin lubricador automático)**

Se enciende cuando el mecanismo de corte de la versión Cross-Cut (cruzado) se tiene que engrasar. El proceso de engrase se tiene que confirmar con el pulsador de retroceso (Fig. 2/5) (ver descripción en „Mantenimiento del mecanismo de corte sin lubricador automático“, p. 32).

**b) "Cambio del recipiente de aceite" (Máquinas con lubricador automático)**

El indicador de control parpadea cuando el recipiente de aceite está vacío y tiene que sustituirse por un recipiente lleno. El motor se desconecta.

El cambio del recipiente de aceite debe confirmarse con el pulsador de retroceso (Fig. 2/5) (consulte „Mantenimiento del mecanismo de corte con lubricador automático“, p. 32).

**! ¡NOTA!**

El motor se desconecta cuando este indicador parpadea y solo se puede volver a encender cuando se haya sustituido el recipiente de aceite vacío por uno lleno.

**⑧ = Indicador de control (Fig. 2/8)**

Para el modo de proceder consulte la descripción correspondiente en el apartado „Avería“, p. 31.

**a) "Material atascado en el aparato"**

Se encenderá al introducir demasiado material en el mecanismo de corte. El mecanismo de corte se bloquea, retrocede a continuación un poco y se para. El motor se desconecta.

**b) "Barrera fotoeléctrica tapada por apertura de puerta"**

Se enciende si al abrir la puerta sigue habiendo material en una de las dos ranuras de alimentación. El mecanismo de corte se para. El motor se desconecta.

**c) "Barrera fotoeléctrica tapada por conexión"**

Se enciende si al conectar la máquina sigue habiendo material en una de las dos ranuras de alimentación.

**⑨ = Indicador de control (Fig. 2/9) "Grado de carga del motor"**

Indica durante el proceso de desmenuzamiento el grado momentáneo de carga del motor mediante una luz determinada por el color (ver descripción „Indicador dinámico de carga“, p. 31).

**Barrera fotoeléctrica**



Fig. 3 Barrera fotoeléctrica

Inicia el proceso de desmenuzamiento al introducir material en la ranura de alimentación (Fig. 3/1).

Al mismo tiempo se encenderá el indicador piloto del pulsador de avance.

### 3.2 Cómo conectar el aparato

Accione brevemente el pulsador funcional (Fig. 2/1).

- El indicador piloto del pulsador  se encenderá para la función "Listo para el uso".
- A continuación se puede empezar a alimentar el aparato.

### 3.3 Alimentación de material



#### ¡Atención!

##### ¡Daños a la máquina!

- △ ¡No introduzca nunca en el aparato más material del indicado como máximo (consulte el apartado „Datos técnicos“, p. 34)!
- △ En el caso de que se haya introducido de todos modos demasiado material en el mecanismo de corte, consulte en „Material atascado en el aparato“, p. 31.

Insertar el papel hacia el mecanismo de corte por la rendija de entrada (Fig. 3/1).

- La máquina conmuta automáticamente al avance insertando el papel.
- Tras el proceso de trituración se desconecta automáticamente el motor.



#### ¡NOTA!

Para el desmenuzamiento de láminas transparentes se tiene que conectar la máquina a mano en el modo de funcionamiento de avance (mantenga accionado el pulsador de avance (Fig. 2/2)).

Si la máquina no se utiliza durante un periodo de tiempo de aprox. 15 min. se desconecta.

### 3.4 Cómo vaciar el recipiente de recogida

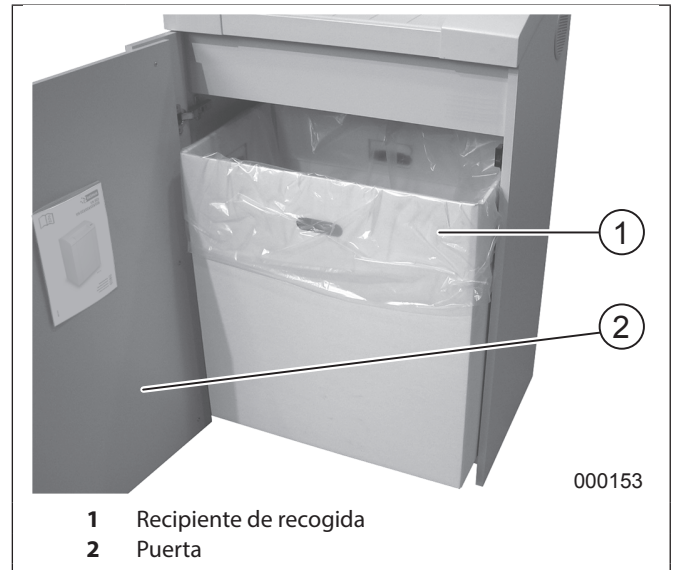



Fig. 4 Recipiente de recogida

Si el recipiente recogedor está lleno, el motor se desconecta. El indicador de control  (Fig. 2/4) se enciende.







#### ¡NOTA!

Para finalizar el proceso de desmenuzamiento con el motor desconectado, mantenga accionado el pulsador de avance (Fig. 2/2).

- El mecanismo de corte seguirá avanzando unos cuatro segundos.

Este proceso solo se puede activar una vez.

Vaciar ahora el o los recipientes de recogida (Fig. 4/1) como se indica a continuación:

1. Abra la puerta (Fig. 4/2).
  - El indicador de control  (Fig. 2/6) se enciende.
  - Si aún queda material en la ranura de alimentación, el indicador de control  (Fig. 2/8) se encenderá también ahora.
2. Retire el saco lleno y elimine el contenido.
  - El indicador de control  (Fig. 2/4) se apaga.
3. Coloque el saco vacío.
4. Cierre la puerta.
  - El indicador de control  (Fig. 2/6) se apaga.
5. Si el indicador de control  está encendido, confirme brevemente con el pulsador de avance (Fig. 2/2). El material que se había quedado en la ranura de alimentación es desmenuzado y el indicador se apaga.



#### ¡NOTA!

¡La máquina sólo funciona con la puerta cerrada!

### 3.5 Indicador dinámico de carga

Durante el proceso de desmenuzamiento, un indicador de control (Fig. 2/9) muestra el grado de carga del motor:

- Luz verde: Carga < 75 %
- Luz roja: Carga 75 -100 %

El indicador de control debe permanecer en color verde para evitar un atasco de material.

#### ¡NOTA!

¡El sistema indicador de carga se calibra automáticamente! Por ello el indicador de carga puede mostrar cosas diferentes. (Por ejemplo, si se enciende en rojo sin carga). Esto no es un fallo de funcionamiento. Después de triturar varias veces se regula de nuevo el sensor de carga.

### 3.6 Modificación del caudal de aceite

(Sólo máquinas con lubricador automático)

El caudal del lubricador automático puede ajustarse según sus necesidades.

#### a) Ample Mode

Las bombas de aceite llevan aprox. un 25 % **más** de aceite al mecanismo de corte que en el modo normal.

#### b) Normal Mode

es el ajuste estándar.

#### c) Scarce Mode

Las bombas de aceite llevan aprox. un 25 % **menos** de aceite al mecanismo de corte que en el modo normal.

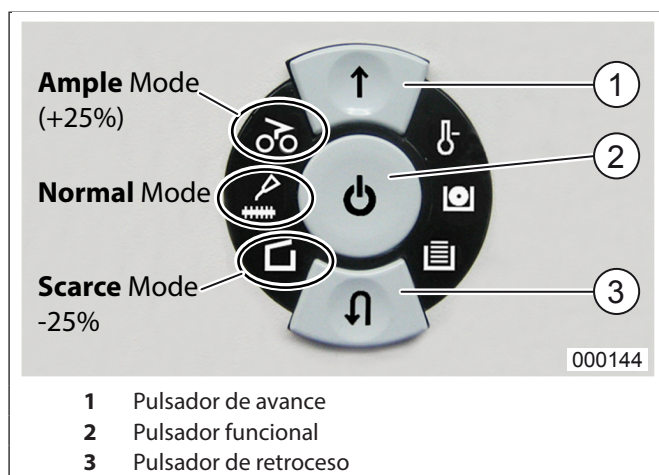

Fig. 5 Modificación del caudal de aceite

Para la modificación del caudal de aceite, proceda de la siguiente manera:

1. ¡La máquina debe estar desconectada!
2. Abra la puerta.
3. Mantenga accionados a la vez el pulsador de avance (Fig. 5/1) y el de retroceso (Fig. 5/3).



4. Pulse y vuelva a soltar también el pulsador de función (Fig. 5/2).
  - Todos los LED se iluminan.
5. Suelte el pulsador de avance y retroceso.
  - Se encuentra en el modo de almacenamiento.
6. Accione **dos veces** el pulsador de avance (Fig. 5/1).
  - Se encuentra en el modo de ajuste del caudal de aceite.
  - El LED de la izquierda parpadea e indica el ajuste actual.
7. Accione repetidamente el pulsador de función (Fig. 5/2) hasta que se ilumine el nivel del caudal de aceite deseado (Fig. 5).
  - El nivel del caudal de aceite (Ample, Scarce, Normal) se modifica cada vez que se acciona el pulsador.
8. Accione el pulsador de retroceso.
  - Se vuelve a encontrar en el modo de almacenamiento.
9. Accione el pulsador funcional.
  - Se guardará el ajuste seleccionado.
  - La máquina se apagará.
10. Cierre la puerta.

Si desea continuar con el triturado, vuelva a encender la máquina: Accione brevemente el pulsador funcional (Fig. 5/2).

## 4 Avería

### 4.1 Material atascado en el aparato (Función de auto-retroceso)

Si se produce un atasco debido a un exceso de material introducido, el aparato reacciona como sigue:

- El mecanismo de corte se bloquea, retrocede a continuación un poco (material se libera) y se para.
- El motor se desconecta.
- El indicador de control  (Fig. 2/8) se enciende. Proceda como sigue:
  1. Retire el papel que se ha atascado o accione brevemente el pulsador de avance (Fig. 2/2).
    - Una vez hecho esto, el mecanismo de corte avanzará automáticamente y desmenuzará el resto de papel contenido en el mecanismo de corte. El indicador piloto integrado  del pulsador de avance (Fig. 2/2) está encendido durante el avance. El indicador de control  se apaga.
  2. Continúe con el desmenuzamiento introduciendo una cantidad menor de papel.

## 4.2 Barrera fotoeléctrica tapada por apertura de puerta

Si al abrir la puerta se encontrara aún material en la ranura de alimentación, el motor se desconectará y el mecanismo de corte se parará. El indicador de control  (Fig. 2/8) se enciende.

Cierre la puerta y confirme la situación accionando brevemente el pulsador de avance (Fig. 2/2). El material restante se introducirá en el mecanismo de corte para ser desmenuzado.

## 4.3 Barrera fotoeléctrica tapada por conexión



Si al conectar la máquina hubiera material en la ranura de alimentación, el indicador de control se encenderá  (Fig. 2/8).

1. Retire el material o
2. Accione brevemente el pulsador de avance (Fig. 2/2).
  - El material restante se introducirá en el mecanismo de corte para ser desmenuzado.

## 4.4 Guardamotor

Si el motor se sobrecarga, se desconectará. El indicador de control  (Fig. 2/3) se enciende. Deje enfriar el aparato unos 15 - 20 minutos (en función del modelo y temperatura ambiental) y vuelva a activar entonces el aparato.

## 4.5 Avería eléctrica

Si el indicador piloto  del interruptor funcional (Fig. 2/1) parpadea o sólo el indicador de control  (Fig. 2/6), significa que ha surgido una avería eléctrica.

1. Desconecte la máquina una vez.
2. Vuelva a conectar la máquina.
  - Esto es útil en muchos casos.

Si la máquina sigue sin encenderse, notifíquelo al comercio especializado más cercano.

## 4.6 Lista de verificación en las averías

Si el aparato no funciona, compruebe los siguientes puntos:

- ¿Se ha conectado la clavija de enchufe a la red de corriente eléctrica?
- ¿Está la puerta cerrada?
- ¿Está lleno el recipiente de recogida?
  - Siga las instrucciones en el apartado „Cómo vaciar el recipiente de recogida“, p. 30.
- ¿Hay material atascado en el aparato?
  - Siga las instrucciones en el apartado „Material atascado en el aparato“, p. 31.

- ¿Se ha sobrecargado el motor?
  - Consulte el apartado „Guardamotor“, p. 32.

### ! ¡NOTA!

En muchos casos, es útil reiniciar la máquina:

1. Desconecte la máquina una vez.
2. Vuelva a conectar la máquina.

Si su aparato presenta otro problema distinto a los alistados anteriormente, notifíquelo al comercio especializado más cercano.

## 5 Mantenimiento / Eliminación





### 5.1 Mantenimiento del mecanismo de corte sin lubricador automático

Después de haber transcurrido 30 min de servicio, se deberá aplicar aceite en los mecanismos de corte cruzado. Si el indicador de control está encendido  (Fig. 2/7), proceda como sigue:

Distribuya algo del aceite especial adjunto sobre una hoja de papel. A continuación, lleve la hoja de papel al mecanismo de corte por la ranura de alimentación.

El papel se retraerá y, al mismo tiempo, el aceite alcanzará también el mecanismo de corte para realizar la lubricación necesaria.

Para borrar el indicador, habrá que confirmar este proceso, después de haber engrasado el mecanismo de corte, como sigue:

1. Abra la puerta hasta que el indicador de control  (Fig. 2/6) se encienda. Los indicadores de control  y  parpadean.
2. Accione el pulsador de retroceso (Fig. 2/5) y no lo suelte hasta que el indicador de control  se apague.
3. Cierre la puerta de nuevo.

Una vez hecho esto, el mecanismo de corte comenzará automáticamente un ciclo de limpieza (avance/retroceso) y, a continuación, se desconecta. La máquina vuelve a estar lista para el uso. Si desea pedir el aceite especial, consulte el apartado „Accesorio“, p. 34.

### 5.2 Mantenimiento del mecanismo de corte con lubricador automático

Las unidades de corte transversal deben engrasarse con regularidad tras un tiempo de funcionamiento específico. Esto se efectúa automáticamente mediante la aceitera integrada.



Si el indicador de control  (Fig. 2/7) parpadea, normalmente el recipiente de aceite (Fig. 6/3) está vacío y tiene que sustituirse por un recipiente lleno. Se desconecta el motor.

**! ¡NOTA!**

Para finalizar el proceso de desmenuzamiento con el motor desconectado, mantenga accionado el pulsador de avance (Fig. 2/2).

- El mecanismo de corte seguirá avanzando unos cuatro segundos.

Este proceso solo se puede activar una vez.

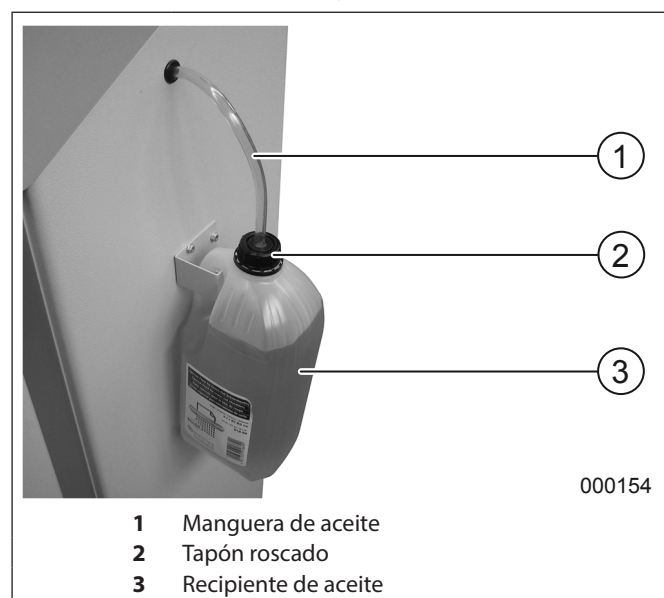

**Cambiar el recipiente de aceite:**

1. Abra la puerta.
  - El indicador de control  (Fig. 2/6) se enciende.
  - El indicador de control del pulsador de retroceso (Fig. 2/5) y indicador de control Engrasar mecanismo de corte (Fig. 2/7) parpadea.



- 1 Manguera de aceite
- 2 Tapón roscado
- 3 Recipiente de aceite

Fig. 6 Recipiente de aceite

2. Soltar el capuchón (Fig. 6/2), retirar la manguera de aceite con el capuchón del recipiente vacío y retirar el recipiente.
3. Colgar el recipiente lleno y retirar el capuchón. Introducir la manguera de aceite (Fig. 6/1) en el recipiente y volver a cerrar el recipiente con el capuchón que se encuentra en la manguera de aceite.
4. Accione el pulsador de retroceso (Fig. 2/5).
  - El indicador de control  (Fig. 2/5) se apaga.
5. Cierre la puerta.
  - El indicador de control  (Fig. 2/6) se apaga.
  - El indicador de control  (Fig. 2/7) se apaga.

La máquina vuelve a estar lista para el uso. Si desea pedir el aceite especial, consulte el apartado „Accesorio“, p. 34.

### 5.3 Limpieza de las fotocélulas



Fig. 7 Limpieza de las fotocélulas

En el caso de que se hayan quedado papeles adheridos en la ranura de entrada (p. ej. tras un atasco de papel) es posible que el aparato no se desconecte a causa de la fotocélula “tapada”.

Puede retirar los trozos de papel o bien limpiar la fotocélula, alimentando el mecanismo de corte con una hoja de papel adicional, o activar la marcha de retroceso del aparato pasando, a continuación, brevemente un pincel sobre ambas “ópticas” de la fotocélula (Fig. 7).

### 5.4 Función automática de ahorro energético

Si el aparato no se utiliza durante algún tiempo, se desconectará automáticamente tras unos 15 min. El indicador piloto  del pulsador funcional (Fig. 2/1) para “Listo para el uso” se apaga. Accione brevemente el pulsador funcional para reconectar.

### 5.5 Eliminación del aparato usado



Elimine el aparato usado al final de su vida útil respetando siempre las normas medioambientales. No tire las partes de la máquina ni el embalaje con la basura doméstica.



## 6 Datos técnicos

Tamaño de corte	
175SP2(SC2):	3,8 mm (tiras) 5,8 mm (tiras)
175CP4(CC3):	4x40 mm (Cross-Cut)
175CP5(CC4):	1,9x15 mm (Cross-Cut)
175CP6(CC5):	0,8x12 mm (Cross-Cut)
175CP7(CC6):	0,8x4,5 mm (Cross-Cut)
Velocidad de corte	
175SP2(SC2):	0,12 m/sec.
175CP4(CC3)/CP5(CC4):	0,13 m/sec.
175CP6(CC5):	0,15 m/sec.
175CP7(CC6):	0,23 m/sec.
Rendimiento de corte	
175SP2(SC2) 3,8 mm	40-45 hojas (70g/m <sup>2</sup> )
175SP2(SC2) 5,8 mm	65-70 hojas (70g/m <sup>2</sup> )
175CP4(CC3):	40-50 hojas (70g/m <sup>2</sup> )
175CP5(CC4):	25-30 hojas (70g/m <sup>2</sup> )
175CP6(CC5):	15-17 hojas (70g/m <sup>2</sup> )
175CP7(CC6):	8-10 hojas (70g/m <sup>2</sup> )
<b>Tensión de conexión:</b>	230 V/50 Hz, 240 V/50 Hz, 120 V/60 Hz, 100V/50/60Hz
<b>Fusible previo (lento):</b>	230 V/50 Hz = 16 A 240 V/50 Hz = 13 A 120 V/60 Hz = 20 A
<b>Ancho de trabajo:</b>	405 mm
<b>Nivel de ruidos:</b>	aprox. 52 dB (A)
<b>Potencia:</b>	1,1 kW
<b>Dimensiones (AxFxAl):</b>	660 x 560 x 1050 mm
<b>Peso:</b>	aprox. 90 kg

## 7 Accesorio

Denominación	Nº de pedido
Saco de plástico, 600 x 500 x 1000 x 0,05 mm	99952
Botellita de aceite, 110 ml	88035
Recipiente de aceite, 2000 ml	91869



### ¡NOTA!

En el caso de pedidos posteriores de accesorios y de piezas de repuesto, rogamos se dirija a nuestro representante oficial.

## 8 Certificate of Conformity

### Konformitätserklärung Certificate of Conformity Attestation de Conformité Certificado de Conformidad



Bezeichnung der Maschine:	<b>Datenshredder</b>
Type of machine:	Document Shredder
Description de la machine:	Destructeur de Document
Descripción de la máquina:	Destructora de Documentos
Modell / Model / Modèle / Modelo:	<b>intimus 175SP2(SC2) intimus 175CP4(CC3) intimus 175CP5(CC4) intimus 175CP6(CC5) intimus 175CP7(CC6) intimus 175 hybrid</b>
Typ / Type / Type / Tipo:	<b>297-4S + 297-6S 297-4C+297-2C+297-1C+297-1CF+297-1CH</b>
Artikel-Nr. / item number / numéro d'article / número de la pieza:	297101-297999
Serien-Nr. / serial number / numéro de série / número de serie:	siehe Typenschild / see name plate voir plaque d'identification / mirar la placa de identificación
Baujahr / year of manufacture / année de production / año de producción:	siehe Typenschild / see name plate voir plaque d'identification / mirar la placa de identificación

Hiermit wird bestätigt, dass vorgenanntes Produkt den Anforderungen der **Niederspannungs-Richtlinie 2006/95/EG** sowie der **EMV-Richtlinie 2004/108/EG** einschließlich allen bis heute veröffentlichten Änderungen bzw. Nachträgen entspricht. Der oben beschriebene Gegenstand der Erklärung erfüllt die Vorschriften der **Richtlinie 2011/65/EU** des Europäischen Parlaments und des Rates vom 8. Juni 2011 zur Beschränkung der Verwendung bestimmter gefährlicher Stoffe in Elektro- und Elektronikgeräten. Das vorgenannte Produkt entspricht folgenden harmonisierten bzw. nationalen Normen:

We do hereby certify that the above mentioned product meets the requirements set forth in **EEC-Low-Voltage-Directive 2006/95** and **EMC 2004/108/EEC** including all changes and addendums to date thereto. The object of the declaration described above is in conformity with **Directive 2011/65/EU** of the European Parliament and of the Council of 8 June 2011 on the restriction of use of certain hazardous substances in electrical and electronic equipment. The above mentioned product meets the following harmonized and national standards:

Nous Vous Confirmons que le produit cité ci-dessus correspond aux directives de basse tension **2006/95/CEE** ainsi qu'à la directive **CEM 2004/108/CEE**, ci-inclus toutes les modifications ainsi que tous les suppléments publiés jusqu'à ce jour. L'objet de la déclaration décrit ci-dessus est conforme à la directive **2011/65/UE** du Parlement européen et du Conseil du 8 Juin 2011 sur la limitation de l'utilisation de certaines substances dangereuses dans les équipements électriques et électroniques. Le produit mentionné correspond aux normes citées ci-après:

Confirmamos que los productos arriba citados cumplen las exigencias de las **directivas de baja tensión 2006/95/CEE y CEM 2004/108/CEE**, incluidas todas las modificaciones publicadas hasta la fecha. El objeto de la declaración descrita anteriormente es conforme a la **Directiva 2011/65/UE** del Parlamento Europeo y del Consejo, de 8 de Junio del 2011, sobre restricciones a la utilización de determinadas sustancias peligrosas en aparatos eléctricos y electrónicos. Los productos citados corresponden con las siguientes normas:

<b>EN 61000-3-2:2006+A1:2009+A2:2009</b>	<b>EN 55014-1:2006+A1:2009</b>
<b>EN 61000-3-3:2008</b>	<b>EN 55014-2:1997+A1:2001+A2:2008</b>
<b>EN 61000-4-2:2009</b>	<b>EN 60950-1:2006+A11:2009+A1:2010+A12:2011</b>
<b>EN 61000-4-4:2004</b>	<b>EN ISO 13857:2008</b>
<b>EN 61000-4-5:2006</b>	
<b>EN 61000-4-11:2004</b>	

CE-Bevollmächtigter / authorized person of CE / personne autorisée de la CE / persona autorizada por CE:  
**intimus International GmbH; Berghheimer Straße 6-12; D-88672 Markdorf / Germany**



Postfach / p.o.box 1420  
D-88672 Markdorf / Germany

2018/11  
  
**Javier Ortiz de Zárate**  
Geschäftsführer  
Managing director  
Directeur général  
Director General

## International Network

<b>Germany</b>	intimus International GmbH Bergheimer Straße 6-12 88677 Markdorf / Bodensee	+49 (0) 7544 60-0 sales.de@intimus.com
<b>North America</b>	intimus North America 251 Wedcore Avenue Wabash, IN 46992	(800) 775 2122 sales.us@intimus.com
<b>France</b>	intimus International GmbH Bergheimer Straße 6-12 88677 Markdorf / Bodensee	+33 (6) 14 59 19 41 +33 (6) 12 44 59 05 sales.de@intimus.com
<b>P.R. China</b>	intimus International Trading (Beijing) Limited Room 260D, C Building Guojigang No.E-2 Dong San Huan Bei Road, Chaoyang District, Beijing 100027, PRC	+86 (0) 10 84 47 10 71 / 72 / 73 info@intimus.com.cn
<b>Austria</b>	intimus International Austria Ges. m. b. H. Ernst Melchior Gasse 20, 4. OG Top 6 1020 Wien	+ 43 (0)1 2583621 0 contact.at@intimus.com
<b>Belgium</b>	intimus International Belgium NV Wayenborgstraat 22, 2800 Mechelen	+32 (0)15 - 29 46 30 infobel@intimus.com
<b>Netherlands</b>	intimus International Netherlands, B.V. Rivium Quadrant 2, 6e verdieping 2909 LC Capelle aan den IJssel	+31 (0)10 - 242 11 00 informatie@intimus.com
<b>Luxemburg</b>	intimus International Luxemburg S. à.r.l. Route des Trois Cantons 9 , Ground Floor 8399 Luxembourg	+352 (0)26 - 10 88 66 infolux@intimus.com
<b>Portugal</b>	intimus International Portugal IIG Mailing and Information Security Portugal Sociedade Unipessoal LDA. Rua Alfredo Lopes Villaverde, 15-B, Escritorio 4, Paço de Arcos e Caixas 2770-009 Lisboa	+351 214 415 153 pt@intimus.com
<b>Spain</b>	intimus International Ibérica, S.A. Antón Fortuny, 14, 16 esc. C1º 1ª Esplugues de Llobregat 08950 Barcelona	+34 93 480 33 10 info.es@intimus.com
<b>Other Countries</b>	intimus International GmbH Bergheimer Straße 6-12 88677 Markdorf / Bodensee	+49 (0) 7544 60-0 sales.de@intimus.com

