

X YRON™ 2500

Adhesive Application and Laminating System

1-800-793-3523

U S E R ' S G U I D E

Adhesive Application & Laminating System



The Xyron™ 2500 is an economical and easy to use document finishing system. This versatile and non-electric system has been designed to laminate or apply mounting adhesive to a variety of media. The same system is capable of laminating, selectively applying adhesive or laminating and applying adhesive at the same time. With the Xyron 2500, documents are easily laminated or can be transformed into signs, stickers or labels instantly. The machine and supplies are compatible with all types of computer-printed media including laser, inkjet, color and thermal in a wide range of material sizes and thickness.

Supply rolls for 2500



- AT400-300 Adhesive Application – High Tack
- AT402-300 Adhesive Application – Low Tack
- AT406-170 Adhesive Application – Repositionable



- DL403-300 Two-Sided Lamination
- SL403-300 One-Sided Lamination



- LAT405-300 Combination Lamination/Adhesive Application - High Tack
- LAT406-300 Combination Lamination/Adhesive Application - Low Tack
- LAT409-170 Combination Lamination/Adhesive Application - Repositionable

Please follow the attached directions carefully.

Understanding the Xyron 2500's Adhesive/Laminating System Parts and Functions

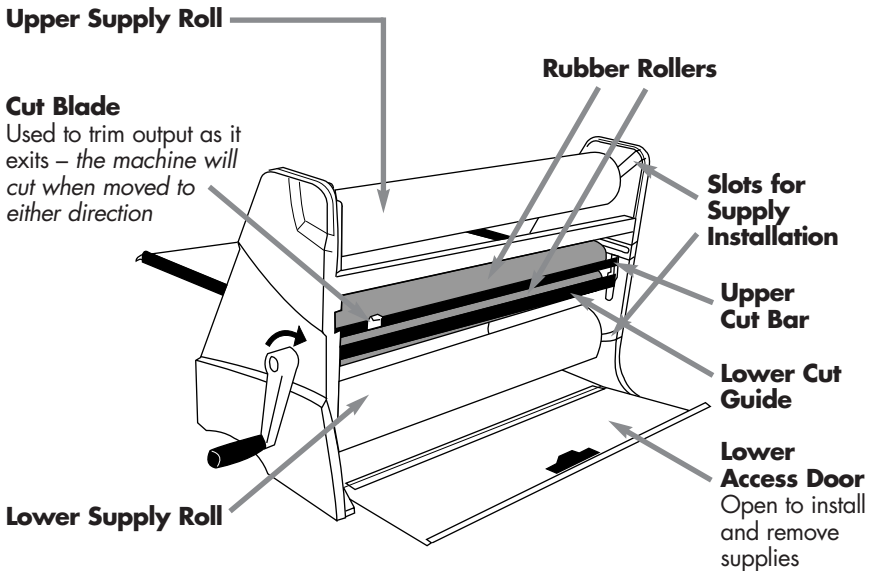
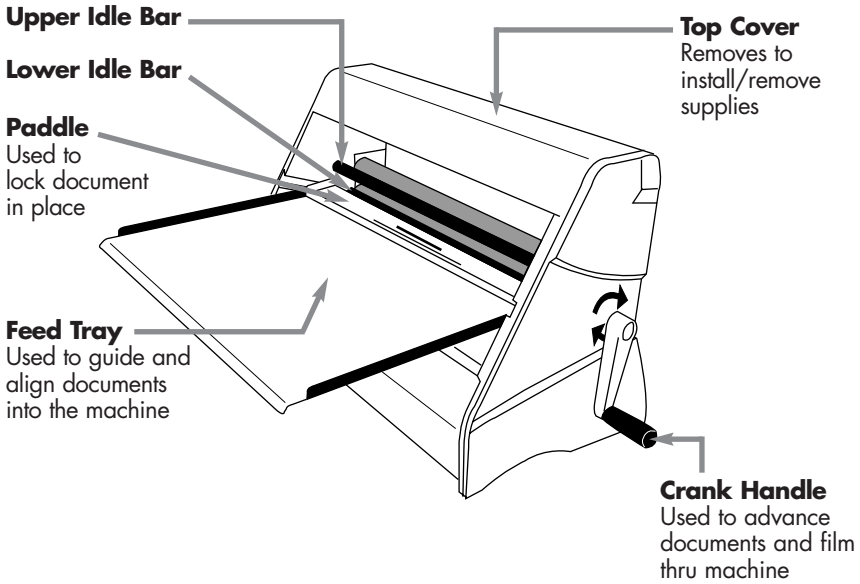

Setting Up

Remove the machine from the packaging and place on a level surface. Locate the crank handle and training video which are taped to the bottom inside of the machine.

Install the crank handle by carefully threading clockwise (direction of the arrows) into the lower rubber roller. Cut the tie wraps holding the upper cut bar and lower guide together.

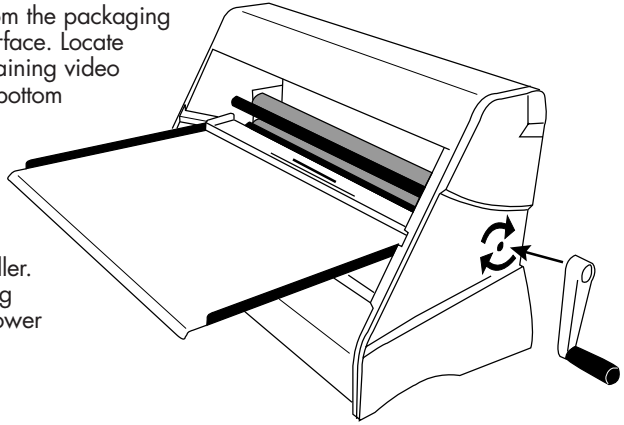

Training Video

The Xyron 2500 comes with an instructional video. In addition to explaining how to load supply rolls, the video also includes tips on how to use the machine. Xyron recommends watching this video before attempting to load and use the 2500.

Loading Supply Rolls

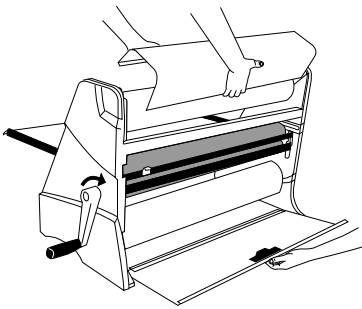

Step 1:

- Remove the top cover of the machine by lifting upward.
- Grasp the handle on the lower access door; pull to open.

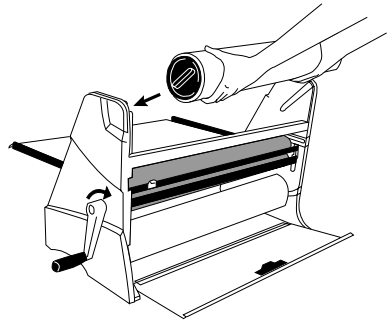

Step 2:

- Match the colored dots on the end of each supply roll with the corresponding dots on the side of the machine. Note which roll is identified as "top" and "bottom".
- Slide the supply rolls into the grooves in the sides of the machine, making certain that the roll is inserted completely.

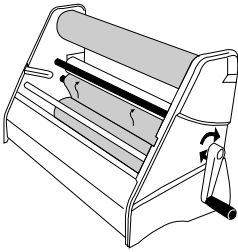

Step 3:

- On the bottom supply roll, grasp the laminated starter section by the leading edge film.
- Route over the bottom idler bar adjacent to the lower rubber roller.
- Make sure the film is inserted squarely. Rotate the handle 1/4 turn in the direction of the arrows.

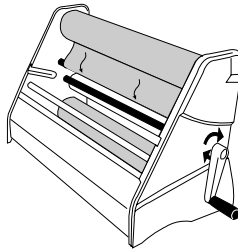

Step 4:

- Make certain the lower film is tight. If necessary, rotate the supply roll in the direction of the arrows until the film is taut.
- Grasp the film from the upper supply roll and adhere it to the film on the lower supply roll.

By carefully aligning the edges, keeping the film tight and avoiding wrinkles, film waste will be minimized.

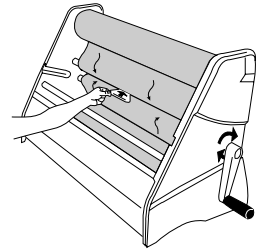

Step 5:

- Rotate the handle to pull the supplies through the machine.
- Ensure that the film exits between the blade bars.
- Just before the top film becomes tight again, insert a small piece of cardstock between the rubber rollers. This will help to minimize waste and ensure the film exits between the upper cut bar and lower guide.

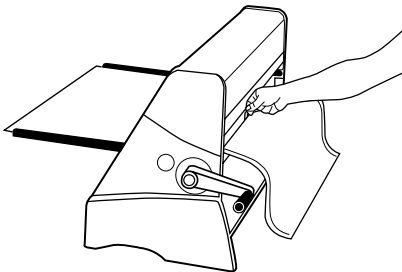

Step 6:

- Continue to crank film through machine until it is aligned and wrinkle-free.
- Trim off excess film by pressing down on the blade holder and sliding in either direction.

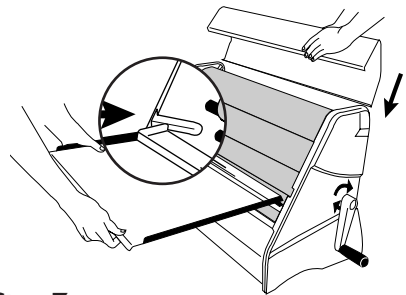

Step 7:

- Replace the top cover.
- Close the lower access door.
- Install feed tray completely by aligning the support posts in the grooves located in the sides of the machine.

When done correctly, the film layers should be aligned and wrinkle-free after 18" (45cm) of material has exited the machine.

How to apply Front & Back Lamination or Front-Side Lamination/Back-Side Permanent Adhesive Transfer

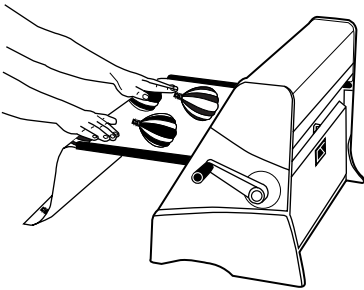

Step 1:

- Pull back on the paddle so that it is in the "up" position.
- Insert a document so the leading edge is under the paddle. The document should extend past the edge of the paddle 1-2 inches (2.5-5cm).

Note: The side of the document which is face down will have adhesive applied when using Front-Side Lamination/Back-Side Permanent Adhesive Transfer.

- Align the document parallel to the edge of the feeder tray.

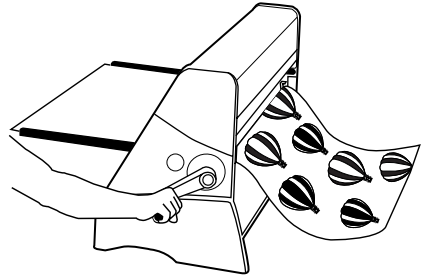

Step 2:

- Push forward on the paddle to lock the document in place.
- Ensure that the leading edge of the document is adhered down evenly. If necessary slide your fingers across the leading edge to secure it in place.
- Turn the handle clockwise to advance the document through the machine.

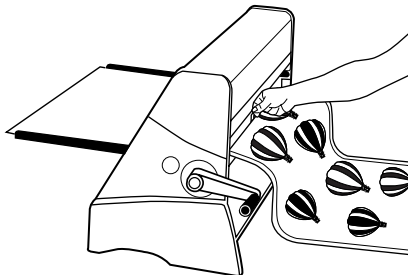

Step 3:

- Trim the document by pressing down on the blade holder and sliding it in either direction.

Note: As the document exits the machine, you may wish to trim the leading edge. This will avoid a later trimming operation.

How to apply Back-Side Permanent Adhesive Transfer

- Steps 1, 2 and 3... same as above.

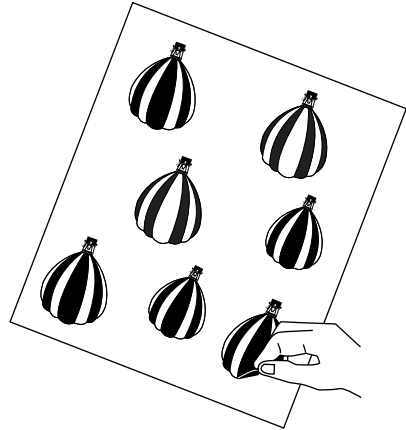
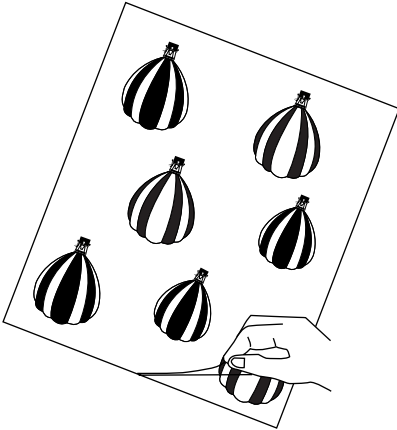

- Remove the protective clear mask layer and discard.
- This process removes excess adhesive from everywhere except the back of the item run through the machine.
- Remove the document from the white release liner when you're ready to mount it.

Replacement Cartridges

Product No.	Description	Applications	Feet Per Roll
AT400-300	Adhesive Application – High Tack	Paste-ups, comps, storyboards & presentations on foam core	300
AT402-300	Adhesive Application – Low Tack	Paste-ups, comps, storyboards & presentations on foam core	300
AT406-170	Adhesive Application – Repositionable	Paste-ups, comps, storyboards & presentations on foam core	170
DL403-300	Two-Sided Lamination	Posters, inkjet & thermal prints & banners	300
SL403-300	One-Sided Lamination	Indoor applications where protection of the rear side is not needed	300
LAT405-300	Combination Lamination/Adhesive Application – High Tack	Paste-ups, comps, storyboards & presentations on foam core, provides protection to top surface	300
LAT406-300	Combination Lamination/Adhesive Application – Low Tack	Paste-ups, comps, storyboards & presentations on foam core, provides protection to top surface	300
LAT409-170	Combination Lamination/Adhesive Application – Repositionable	Paste-ups, comps, storyboards & presentations on foam core, provides protection to top surface	170

Supply Roll Removal

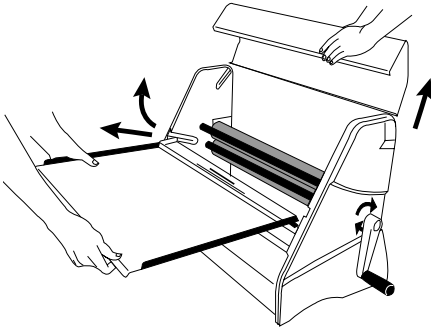

Step 1 —

- Remove the top cover by lifting upward.
- Remove the feed tray by lifting and pulling away from the machine.

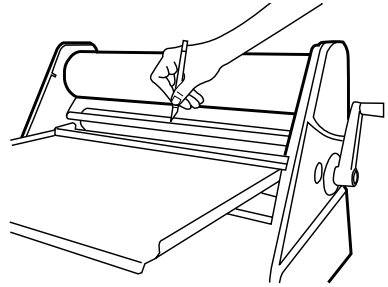

Step 2 —

- Make a small hole with a knife about one inch (2.54cm) from the left edge of the film.
- Slide the knife towards the right edge of the film and stop about one inch (2.54cm) from the edge. Use caution to avoid cutting into the rubber rollers.

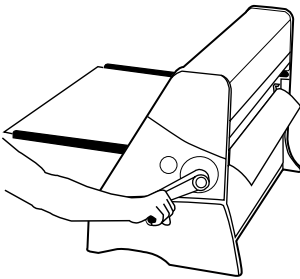

Step 3:

- Turn the handle 1/2 turn **maximum** in the direction of the arrows. This step will cause the uncut film at the edges to break, creating a laminated leader for easy installation at a later time.

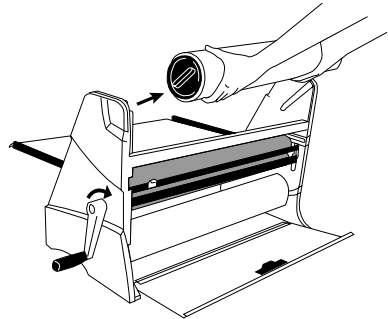

Step 4:

- Remove the supply rolls from the machine. Xyron recommends that supplies are stored laying flat in a cool, dry place using the original packaging.

Maintenance, Safeguards & Tips

When properly used, the Xyron 2500 is relatively maintenance-free. Listed below are safeguards and tips that will produce better results. Refer to the exploded view diagram for part descriptions.

Importance of a clean document:

For best results when laminating, it is highly recommended that the document be cleaned with a soft, lint-free cloth immediately prior to lamination. Small dust or lint particles may cause the laminate to "tent", producing an appearance similar to a small air bubble.

Cut blade replacement and cleaning:

The cut blade may accumulate adhesive over time. Cleaning the blade must be done with great care to avoid personal injury. To remove the blade, slide the orange blade holder into the notch and lift upwards. Carefully remove the blade holder and replace or clean with a light solvent such as isopropyl alcohol.

Use after storage:

For applications where the appearance of your laminated document is critical, it is highly recommended that the Xyron 2500 be used and stored in a clean, dust-free environment. Airborne dust particles and lint will tend to adhere to the bare adhesive inside the supply roll. If the machine has not been used for several days or was subject to a dusty environment, it is recommended that four inches (10cm) of material be advanced and discarded before inserting your document. It is also recommended that the feed tray is cleaned with a lint-free cloth. Contact your dealer about a dust cover as an accessory.

Cleaning adhesive from the nip rollers:

The nip rollers are designed to be self-cleaning under normal use. If adhesive does accumulate, it can normally be removed by first removing the supply films from between the nip rollers and advancing a scrap piece of regular bond paper through the machine. The bare adhesive will tend to attach to the paper. If this method of cleaning does not work, the nip rollers can be cleaned with a light solvent such as isopropyl alcohol. Take care not to scratch, cut or chip the rollers. For best results when laminating, it is critical that the lower idler bar be kept clean of adhesive build-up.

**If You Have Additional Questions, Contact the Xyron Technical Hotline:
800-793-3523 in the U.S.A. and +45-7594-5866 in Europe**

E-mail address in the U.S.A.: comments@xyron.com

E-mail address in Europe: europe@xyron.dk

Also, check out our website at www.xyron.com

Troubleshooting

Symptom	Cause	Solution
Long documents (such as banners) are not aligned with film layers after laminating.	Feed Tray not installed correctly or supply roll not seated at base of groove in side plate(s).	Verify tray is completely installed such that it is approximately level and square. Also, verify supply rolls are completely seated at base of grooves in side plate(s).
Cut Blade does not slide smoothly.	Upper Blade Bar sticking in side plate groove or blade sticking on Blade Bar.	Apply silicon lubricant to all surfaces of top blade bar.
Film does not exit machine between Upper and Lower Blade Bars.	Material is curled or adhesive has been transferred to the Nip Roller causing the film to stick.	Reposition material between upper cut bar and lower guide. Clean adhesive from nip rollers if necessary.
Cut Blade does not cut well.	Blade has accumulated adhesive buildup or is dull.	Clean adhesive buildup from blade using isopropyl alcohol or Xyron Adhesive Cleaner #990. Replace blade if necessary.
Thin and/or wide documents tend to wrinkle during lamination.	Paddle not operated correctly, or tray and/or paddle are not flat	Ensure paddle is pushed forward completely after document is loaded and aligned. Ensure document is extended approximately 1-2" (16mm) past edge of paddle before pushing paddle forward. Also, check that the leading edge of document is evenly adhered ("locked") to lower supply film by temporarily pulling paddle back after it has been completely pushed forward. Check paddle and tray for flatness.
Document difficult to load.	Paddle not pulled back to load position or has adhesive buildup on underside.	Prior to loading document, pull paddle back to "load" position. Ensure underside of paddle is clear of any obstruction or adhesive buildup.
Film wrinkles don't go away as crank is turned clockwise.	Upper and/or lower supply roll(s) are not firmly seated in grooves within side plate(s).	Verify supply rolls are firmly seated at base of grooves in side plates.
Film does not lay flat, curls and/or wrinkles.	Adhesive buildup on lower idle bar.	Clean adhesive buildup from idler roller using isopropyl alcohol or Xyron Adhesive Cleaner #990.

Technical Specifications

Mechanical	Manual crank driven cold lamination
Supplies	Replaceable supply roll sets
Document size (maximum)	25 in. (63.5cm) wide x length of supply 300 ft. (91.4m)
Document thickness range	0.0 to 0.10 in. (2.54mm) Up to 3/16" (4.76mm) foam core mounting board with tray removed
Machine size/ dimensions	(W) 31.5 in. x (L) 28.25 in. x (H) 18.5 in. (W) 80cm x (L) 72cm x (H) 47cm
Footprint	(L) 15 in. x (W) 27.75 in. (L) 38cm x (W) 71cm
Machine weight	Approx. 90 lb. (40.8Kg)

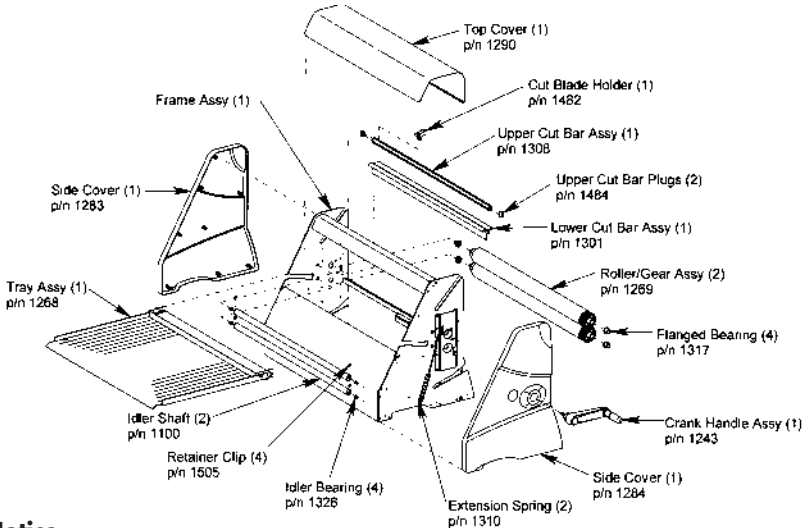

Notice

The information in this manual is subject to change without notice. Xyron shall not be liable for errors contained herein or for incidental or consequential damages in connection with the furnishing, performance or use of this material.

The purchase or acquisition of this product does not confer the right or license to use the machine and cartridges in the retroreflective field or to make or sell machines or cartridges for use in the retroreflective field.

Xyron, Inc. warrants that the Xyron 2500 is free from defects in material and workmanship for a period of one (1) year from the date of purchase. Xyron, Inc. will repair or replace a defective product or part without charge provided it is returned to the address below, freight prepaid with proof of purchase. If the product is damaged by neglect or misuse, the warranty is null and void.

Xyron, Inc.

15820 N. 84th Street,
Scottsdale, AZ 85260

Xyron Europe A/S

Snaremosvej 190 B,
Fredericia, 7000, Denmark

Xyron Technical Hotline
1-800-793-3523 – USA
+45-7594-5866 – Europe

www.xyron.com